



# TRINITY FOREST SPINE TRAIL US 175 at LAKE JUNE ROAD

Bus, Bicycle, Pedestrian





## Trinity Forest Spine Trail

- Construct pedestrian trail bridge parallel to US 175 from Homeview Street to Lake June Road.

## US 175

- Reconstruct center median and shoulders.
- Construct Mechanically Stabilized Earth Walls. (MSE Walls)

## Lake June Road

- Replace and widen existing bridge from 2 to 4 lanes.
- Rehabilitation of existing roadway including full depth repair.
- Replace existing traffic signal at Gillet Street.







## Trinity Forest Spine Trail South Phase

- Loop Dallas project will connect many of Dallas trails into a 50-mile urban trail.
- The project will link 39 miles of existing trail with 11 miles of new trails.
- Unite neighborhoods and enrich daily life with urban trails.
- Connect people with nature.
- Provides a safe pedestrian and cycle option.



# Trinity Forest Trail Original Conceptual Design

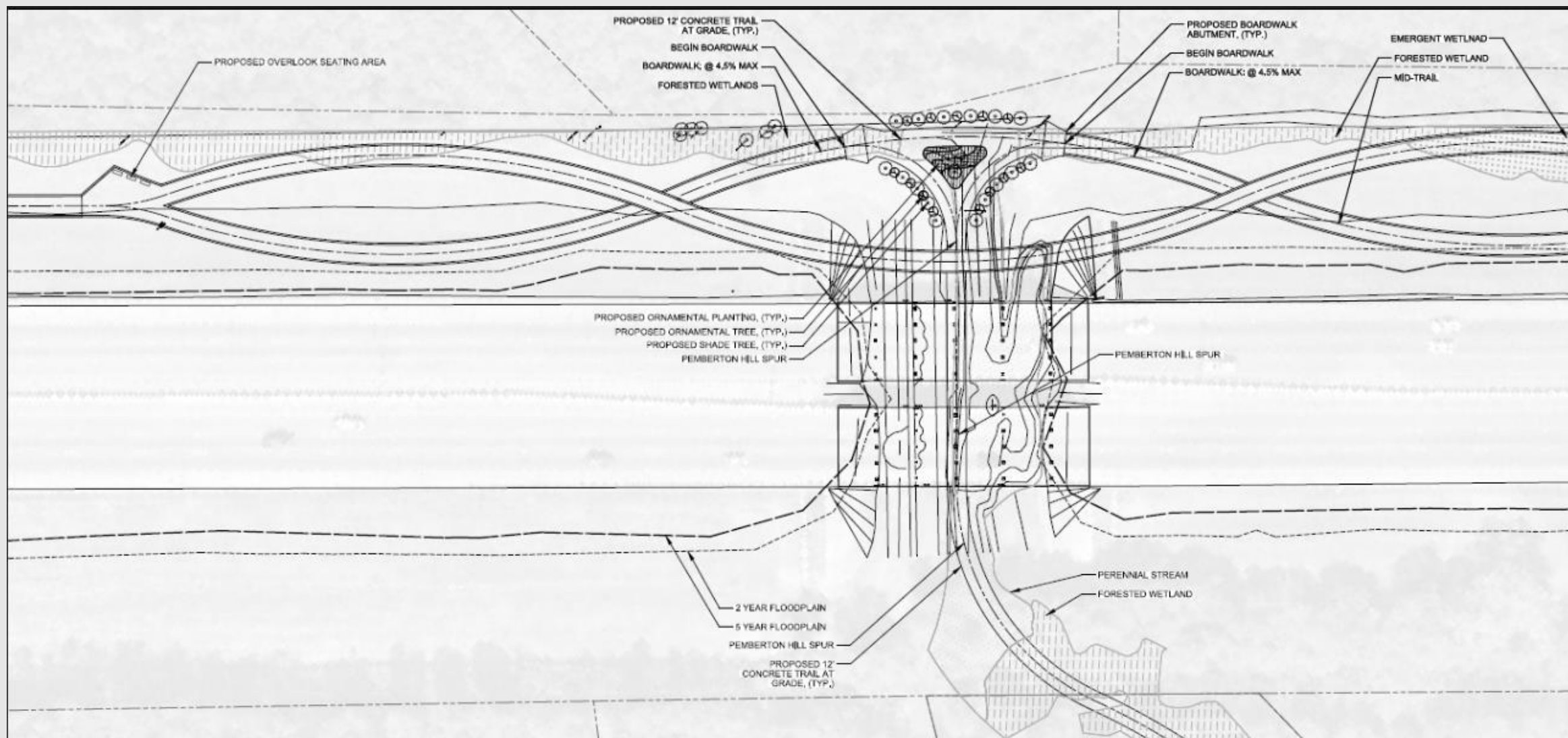



At grade section

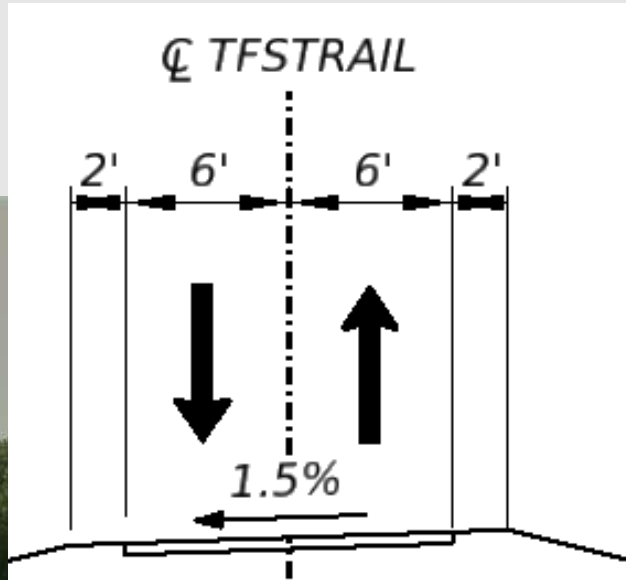

Bridge Section

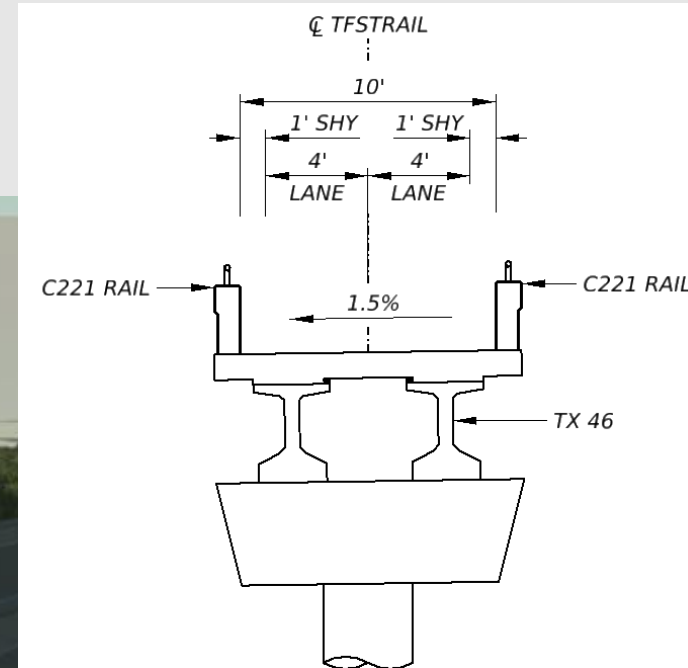



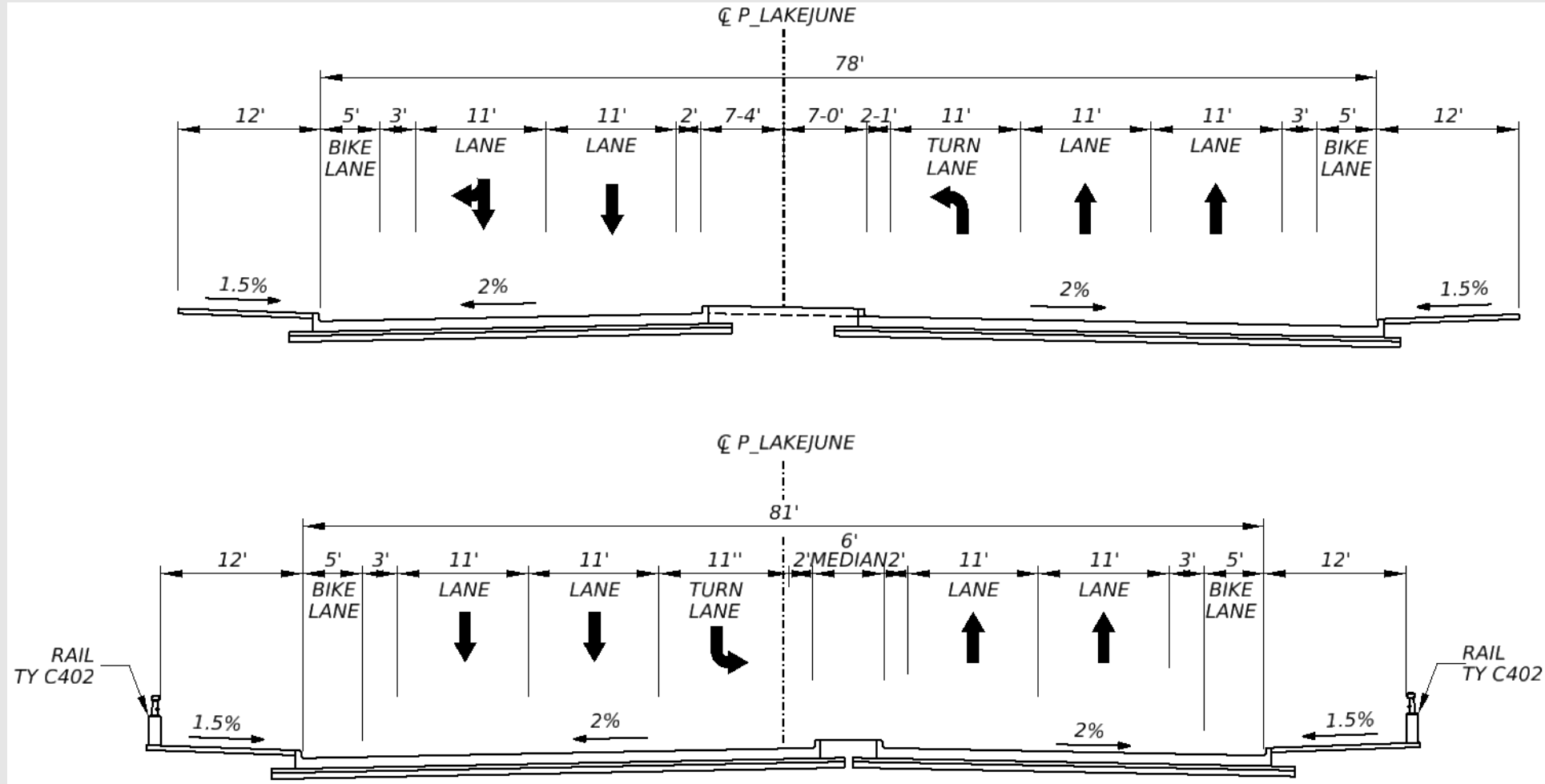

# Lake June Road Bridge

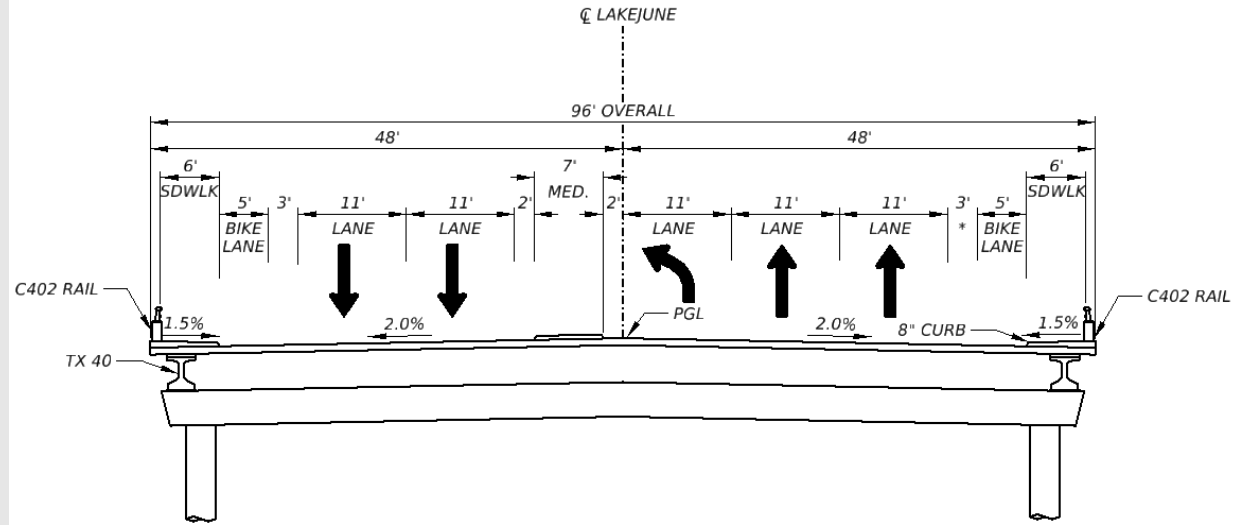

LAKE JUNE RD  
COMPLETED TYPICAL SECTION

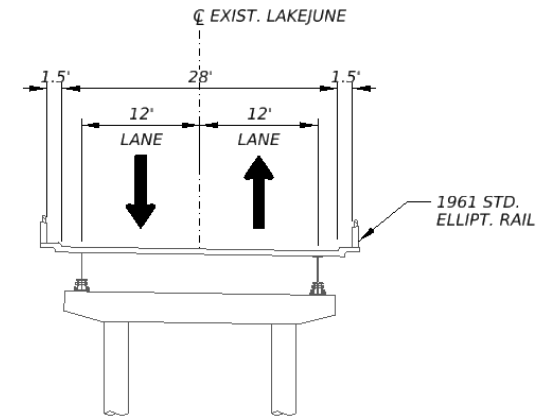

LAKE JUNE RD  
EXISTING TYPICAL SECTION  
EXISTING BRIDGE TO BE REMOVED

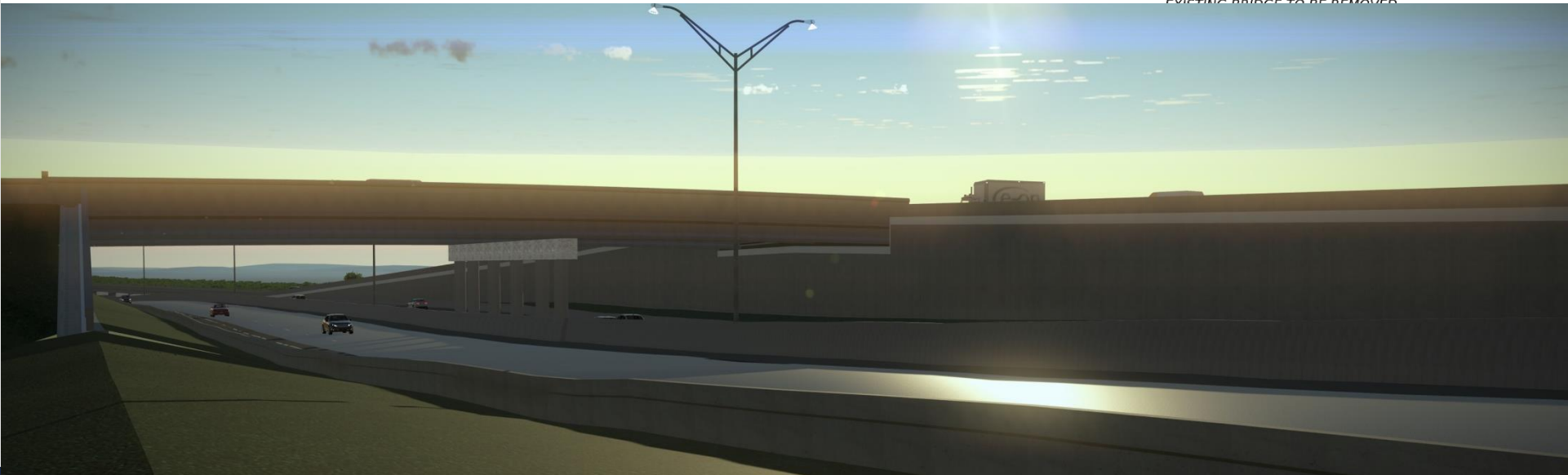

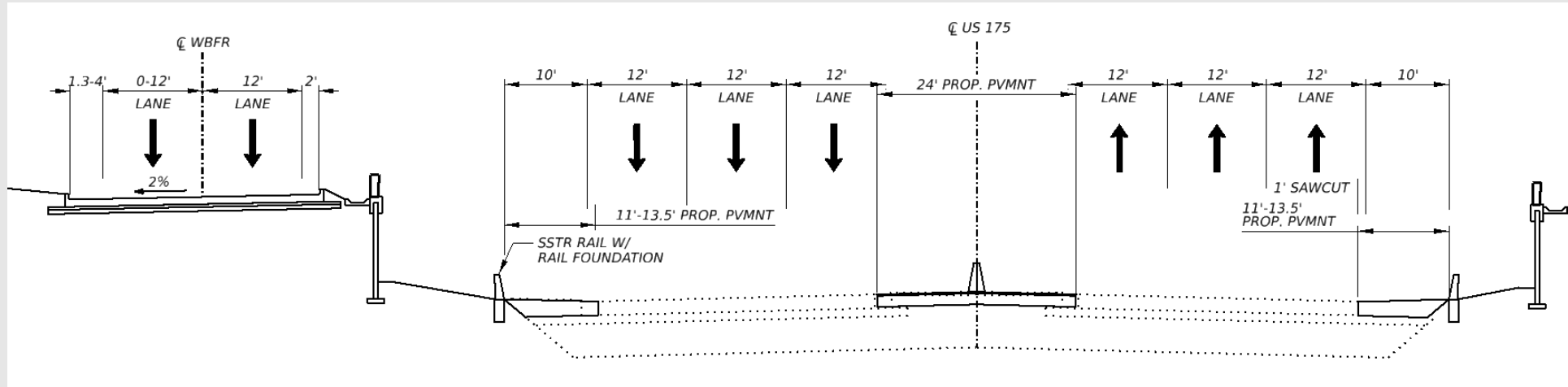



# Project Schedule



- Begin Construction- June 2024
- End Construction- January 2026
- Construction Duration- 20 Months

Contract Time Estimate																				
Rd: US 175																				
CSJ: 0197-02-135, ETC.																				
		= # Days / Cell																		
TASK #	Description	Ju n	Jul (23)	Au g	Se p	Oct (24)	No v	De c	Ja n	Fe b	Mar (23)	Ap r	Ma y	Ju n	Jul (23)	Au g	Se p	Oct (24)	N ov	De c
1	1. Initial traffic control																			
2	2. Detour	█																		
3	3. ROW preparations																			
4	B. Clear and grub	█	█	█																
5	C. Remove old small structures	█	█	█																
6	D. Remove old pavement	█	█	█																
7	E. Remove old curb & gutter	█	█	█																
8	F. Remove old sidewalks	█	█	█																
9	G. Remove old drainage	█	█	█																
10	4. Excavation/Embankment																			
11	A. Earth Excavation		█	█																
12	B. Embankment		█	█																
13	5. Drainage structures																			
14	A. Pipe		█	█																
15	B. Inlets & Manholes		█	█																
16	6. Bridge Structures																			
17	A. Bridge Demolition																			█
18	B. Piling		█	█																
19	C. Footings		█	█																
20	D. Columns		█	█																
21	E. Wingwalls				█	█	█	█	█	█	█	█	█	█	█	█	█	█	█	█
22	F. Beams				█	█	█	█	█	█	█	█	█	█	█	█	█	█	█	█
23	G. Bridge Deck								█	█	█	█	█	█	█	█	█	█	█	█
24	H. Bridge curbs/walks								█	█	█	█	█	█	█	█	█	█	█	█
25	I. Bridge handrails																█	█	█	█
26	7. Retaining Walls																			
27	8. Base preparations																			
28	A. Lime stabilization		█	█																
29	9. Hot mix asphalt base		█	█																
30	10. Concrete paving		█	█																
31	11. Traffic barrier				█	█														
32	12. Permanent signing/signals																			
33	A. Small signs																			
34	B. Overhead signs																			
35	C. Major traffic signals														█	█	█	█	█	█
36	13. Seeding and landscape								█	█					█	█	█	█	█	█
37	14. Pavement markings																			
38	15 Final cleanup																			█
39																				



### FUNDING SOURCES

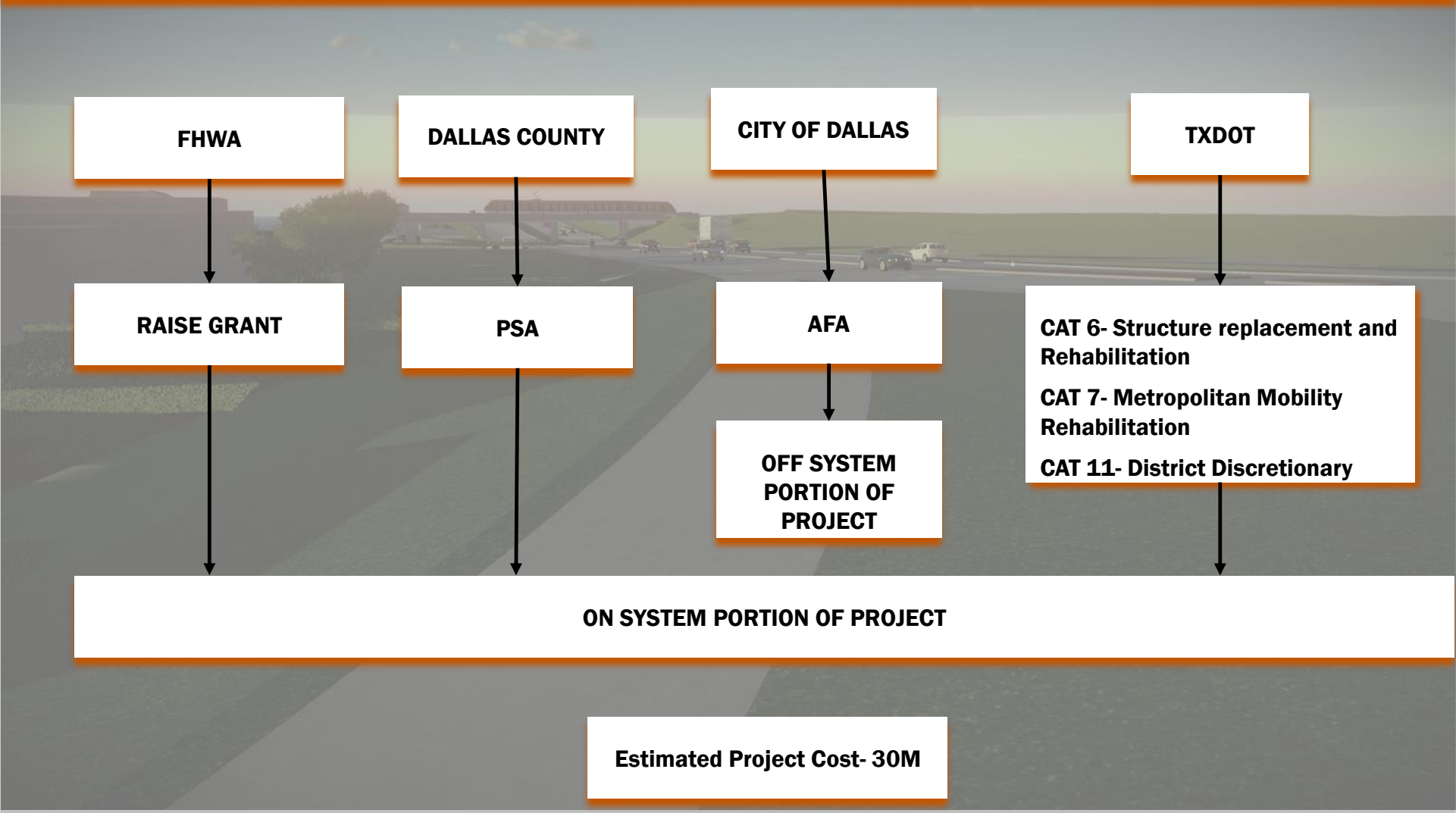



- Begin Date- 10/2022
- Federal Cleared- 8/2023
- LOA Cleared- 1/2024

Activity	REL	Assigned To	Due	Start	End	Milestone	Create	Acceptance	Actions
<b>- Archeology</b>									
Perform Archeology Background Study - 11/17/2022	C	Melanie Johnson	12/16/2022	11/18/2022	11/30/2022	Prior to Env Clearance*	11/17/2022	11/17/2022	
Review Archeology Background Study - 11/28/2022		Brittney Gregory,	12/05/2022	11/28/2022	11/30/2022	Prior to Env Clearance*	11/28/2022	11/17/2022	
Obtain Archeology Section 106/ACT - 11/17/2022		Melanie Johnson	03/20/2023	11/18/2022	12/30/2022	Prior to Env Clearance*	11/17/2022	11/17/2022	
<b>- Biology</b>									
Perform Species Analysis - 11/17/2022		Leslie Mirise	01/16/2023		01/27/2023	Prior to Env Clearance*	11/17/2022	11/17/2022	
Perform Species Analysis - 08/04/2023		Jamila Murchison			08/10/2023	Prior to Env Clearance*	08/04/2023	11/17/2022	
<b>- Community Impacts</b>									
Perform CIA - 11/17/2022					08/09/2023	Prior to Env Clearance*	11/17/2022	11/17/2022	
Review CIA - 11/17/2022		Spencer Ward,	01/16/2023		01/13/2023	Prior to Env Clearance*	11/17/2022	11/17/2022	
<b>- Hazardous Materials</b>									
Perform HazMat ISA - 11/17/2022		Deborah Nixon	01/16/2023		01/12/2023	Prior to Env Clearance*	11/17/2022	11/17/2022	
<b>- Historical Studies</b>									
Obtain Historical Studies Section 106/ACT Approval - 11/17/2022					11/17/2022	Prior to Env Clearance*	11/17/2022	11/17/2022	
Perform Historical Studies PCR - 11/17/2022					11/17/2022	Prior to Env Clearance*	11/17/2022	11/17/2022	
Review Historical Studies PCR - 11/17/2022		Renee BennLee,	01/16/2023		11/17/2022	Prior to Env Clearance*	11/17/2022	11/17/2022	
<b>- Noise</b>									
Noise SME Consultation - 11/17/2022		Meredith Worthen	01/02/2023		11/18/2022	Prior to Env Clearance*	11/17/2022	11/17/2022	
<b>- Project</b>									
Perform CE determination - 11/17/2022				08/21/2023	08/21/2023	Prior to Env Clearance*	11/17/2022	11/17/2022	
Obtain Planning Consistency Documentation - 11/17/2022					08/10/2023	Prior to Env Clearance*	11/17/2022	11/17/2022	
Other Project-Related Information - 11/17/2022						Post Construction	11/17/2022	11/17/2022	
Obtain LOA Clearance - 11/17/2022				01/02/2024	01/02/2024	Prior to LOA	11/17/2022	11/17/2022	
<b>- Protected Lands</b>									
Perform Section 4(f) Analysis - 11/17/2022					03/06/2023	Prior to Env Clearance*	11/17/2022	11/17/2022	
<b>- Public Involvement</b>									
Perform Public Involvement Analysis - 11/17/2022					01/03/2023	Prior to Env Clearance*	11/17/2022	11/17/2022	
Perform OPH/PH - 01/03/2023		Jamila Murchison			08/21/2023	Prior to Env Clearance*	01/03/2023	11/17/2022	
<b>- Water</b>									
Perform Surface Water Analysis - 11/17/2022		Adam Fouts	01/16/2023		01/13/2023	Prior to Env Clearance*	11/17/2022	11/17/2022	





## US 175 TRINITY FOREST TRAIL

Enhancing Quality of Life for All Texans

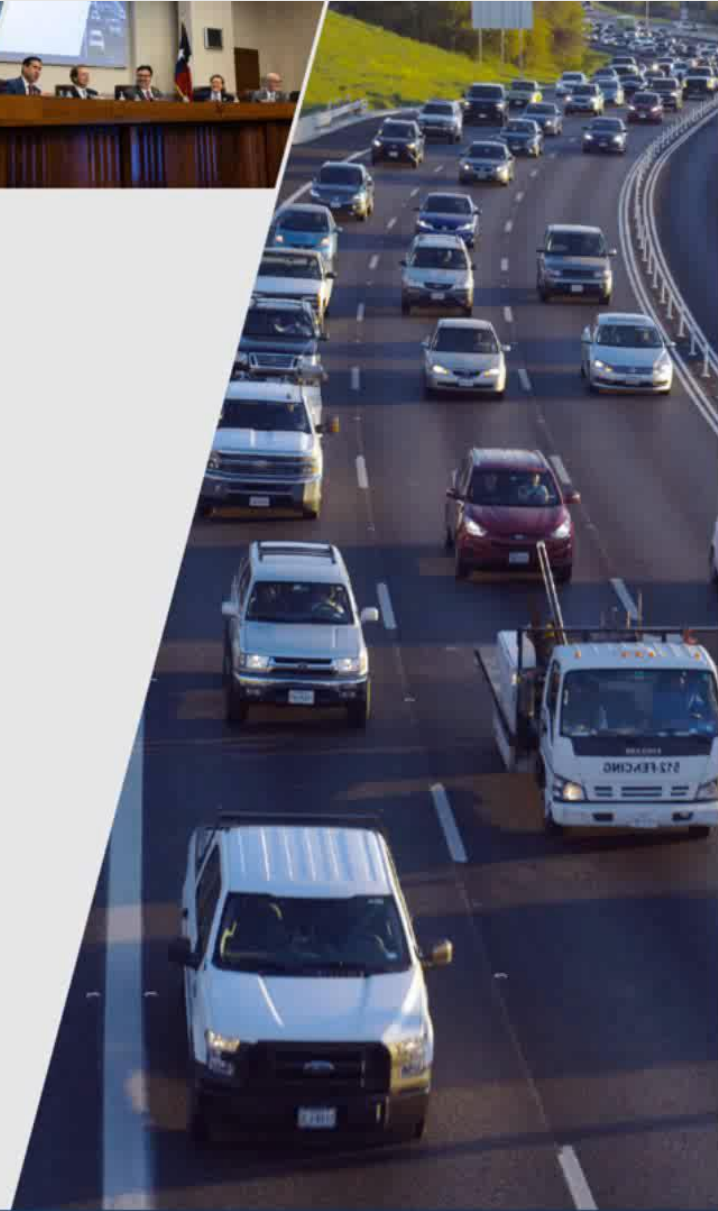

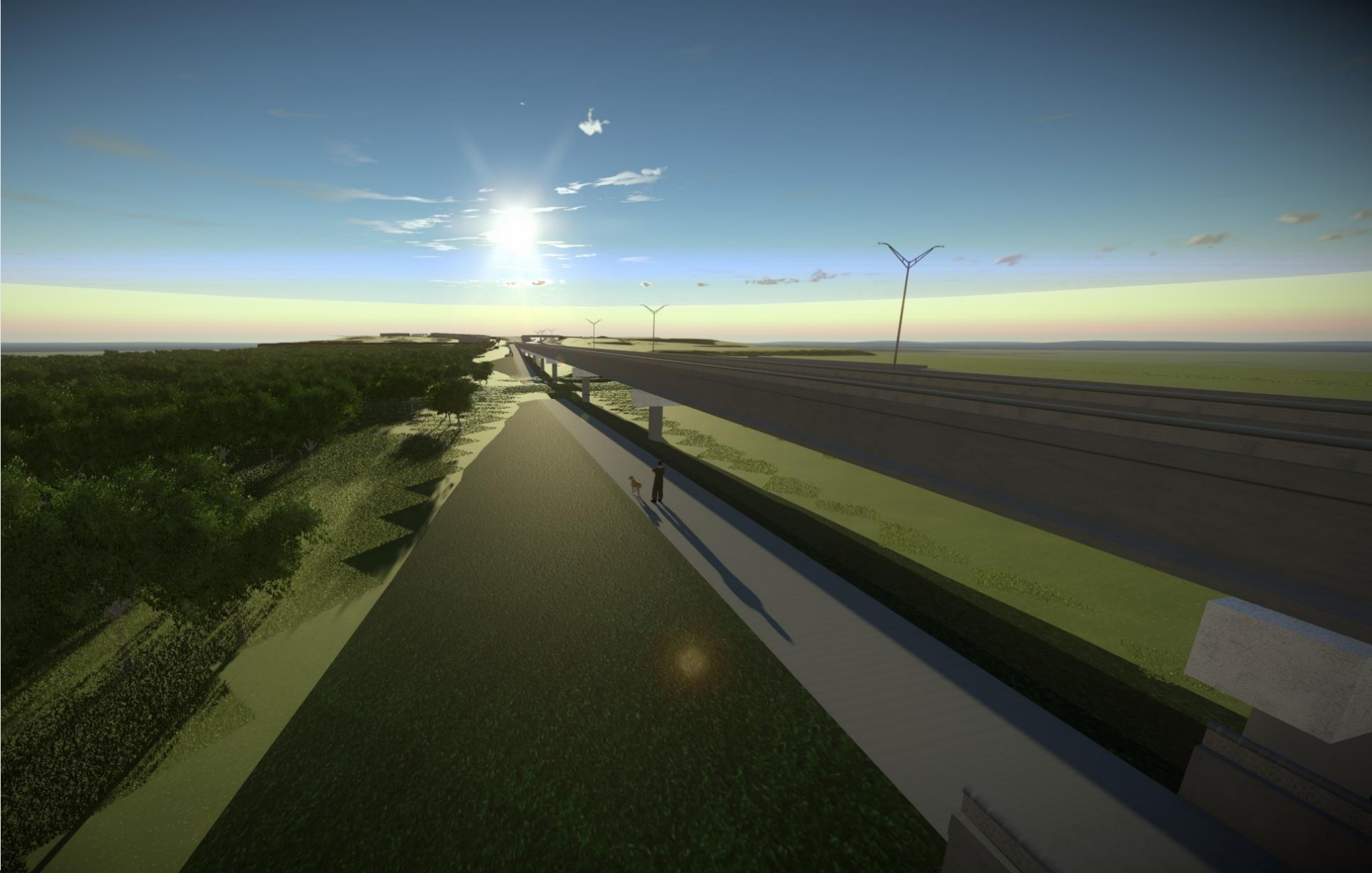





# HELP #EndTheStreakTX

End the streak of daily deaths on Texas roadways.

TxDOT.gov (Keyword: #EndTheStreakTX)



#EndTheStreakTX Toolkit

