



# ABG 1975 HANDBOOK

with Protocol of Signature (PoS),  
Cover Letter (CL) and  
Implementing Instructions (IIs)

June 2024

For U.S. Forces Construction in Germany



*This document contains the full English version of the Auftragsbauten Grundsätze/Principles of Construction Contracting 1975 (ABG 1975) which implements Article 49 of the NATO SOFA Supplementary Agreement.*

**-- THIS PAGE LEFT INTENTIONALLY BLANK--**

**TABLE OF CONTENTS**

<u>CHAPTER</u>	<u>Pg</u>	<u>CHAPTER</u>	<u>Pg</u>
<b>I. FOREWORD</b>	7	<b>SECTION B - RESPONSIBILITIES OF THE GERMAN AUTHORITIES AND THE U.S. FORCES</b>	<b>30</b>
<b>II. <u>Supplementary Agreement (SA) to the NATO SOFA - Article 49 - Construction, Article 53 - Rights Respecting Installations and Article 53A - Special Permits and Licenses in Connection with Use of Installations</u></b>	8	<a href="#">Article 7 [Tasks of the German Authorities]</a>	30
<b>III. ABG 1975 + Protocol of Signature (PoS / UP), Cover Letter (CL / BglB) &amp; Implementing Instructions (IIs / RiABG)</b>	16	<a href="#">Article 8 [Special Types of Contracts]</a>	35
<b>PART I - GENERAL</b>	17	<a href="#">Article 9 [Adherence to the Principle of Economical Efficiency, Timelines and Safety and Security Requirements]</a>	36
<a href="#">Article 1 [Terms and Definitions]</a>	17	<a href="#">Article 10 [Letter(s) of Request on Execution Requirements]</a>	37
<a href="#">Article 2 [Direct vs. Indirect Procedures]</a>	19	<a href="#">Article 11 [Description of Construction Works]</a>	38
<a href="#">Article 3 [Program Coordination]</a>	20	<a href="#">Article 12 [Funding Procedures]</a>	38
<b>PART II - EXECUTION OF CONSTRUCTION WORKS THROUGH THE GERMAN AUTHORITIES (INDIRECT PROCEDURE)</b>	23	<a href="#">Article 13 [Inspections; Determination of Deficiencies]</a>	40
<b>SECTION A - EXECUTION</b>	23	<a href="#">Article 14 [Turnover; Final Inspection]</a>	40
<a href="#">Article 4 [Adherence to Legal and Administrative Regulations]</a>	23	<a href="#">Article 15 [Procedure and Costs in case of Disputes]</a>	41
<a href="#">Article 5 [Solicitation and Award Procedures]</a>	27	<b>SECTION C - COSTS TO BE BORNE BY THE U.S. FORCES</b>	<b>43</b>
<a href="#">Article 6 [Exemption from Payment of Taxes and Duties]</a>	29	<a href="#">Article 16 [Costs to be Borne by the Forces]</a>	43

## TABLE OF CONTENTS

<u>CHAPTER</u>	<u>Pg</u>	<u>CHAPTER</u>	<u>Pg</u>
<a href="#">Article 17 [Special Cases of Costs to be Borne by the Forces]</a>	45	<b>PART III - EXECUTION OF CONSTRUCTION WORKS BY THE FORCES WITH THEIR OWN PERSONNEL OR LABOR EMPLOYED BY THEM DIRECTLY (DIRECT PROCEDURE)</b>	<b>62</b>
<a href="#">Article 18 [Cases of Costs not to be Borne by the Forces]</a>	45	<b>SECTION A - GENERAL</b>	<b>62</b>
<a href="#">Article 19 [Construction Site Offices; Construction Site Supervision]</a>	45	<a href="#">Article 27 [Allowable Direct Construction Work]</a>	62
<b>SECTION D - COMPENSATION OF THE GERMAN AUTHORITIES</b>	<b>47</b>	<a href="#">Article 28 [Application of German Regulations Pertaining to Direct Construction Work]</a>	64
<a href="#">Article 20 [Scope of Compensation]</a>	47	<a href="#">Article 29 [Project Coordination Procedures]</a>	64
<a href="#">Article 21 [Basis of Compensation]</a>	48	<b>SECTION B - PROCEDURES</b>	<b>65</b>
<a href="#">Article 22 [Factors of Computing Compensation]</a>	49	<a href="#">Article 30 [Participation of German Agencies; Detailed Coordination Procedures]</a>	65
<a href="#">Article 23 [Rates of Compensation]</a>	50	<a href="#">Article 31 [Observing Conditions Established by the German Authorities]</a>	66
<a href="#">Article 24 [Compensation in case of Partial Services and Interruption; Costs of Consultants]</a>	52	<a href="#">Article 32 [Compliance with Technical Building Codes]</a>	67
<b>SECTION E - PAYMENT OF THE COST OF CONSTRUCTION WORKS, MISCELLANEOUS</b>	<b>55</b>	<a href="#">Article 33 [Construction Measures Within and Outside Accommodation]</a>	68
<a href="#">Article 25 [Fund Allocation, Invoicing, Examination by the German Federal Audit Office]</a>	55	<a href="#">Article 34 [Review by the Regional Finance Office (OFD)]</a>	68
<a href="#">Article 26 [Compensation Payment Procedures]</a>	58	<a href="#">Article 35 [Authority to Issue Directives; Handling of Objections]</a>	68

## TABLE OF CONTENTS

<u>CHAPTER</u>	<u>Pg</u>	<u>CHAPTER</u>	<u>Pg</u>
<a href="#">Article 36 [Responsibility; Damage Claims; Disputes]</a>	69	ABG-2, <i>Letter of Intent for Direct Procedure (Article 27, ABG 1975)</i>	80
<a href="#">Article 37 [Final Inspection; Correction of Deficiencies Noted by the OFD]</a>	69	ABG-3, <i>Request-/Approval-/Award Document (Article 10, ABG 1975)</i>	81
<a href="#">Article 38 [Cost Settlements]</a>	70	ABG-4, <i>Tender Acceptance Form (Article 7.1.6, ABG 1975)</i>	84
<b>PART IV - TRANSITIONAL AND CONCLUDING PROVISIONS</b>	<b>71</b>	ABG-5, <i>Change Order Document (Article 12, ABG 1975)</i>	86
<a href="#">Article 39 [Authority of Implementing Instructions]</a>	71	ABG-5A, <i>U.S. Forces Change Request (Article 4.2.2, ABG 1975)</i>	89
<a href="#">Article 40 [Amendments to Agreement; Consultations]</a>	71	ABG-6, <i>Order Document for Construction Works under Term Contract (Article 1.8, ABG 1975)</i>	90
<a href="#">Article 41 [Effective Date of Agreement; German and English Text Equally Effective]</a>	72	ABG-7, <i>Joint Minutes - Turnover of Construction Work by the German Building Authority to the U.S. Forces (Article 14, ABG 1975)</i>	91
<b>ANNEX A TO THE PROTOCOL OF SIGNATURE (PoS / UP) TO ABG 1975</b>	<b>73</b>	ABG-7B, <i>Record of the Joint Final Inspection of Construction Work Executed by the U.S. Forces using the Direct Procedure (Article 37.1, ABG 1975)</i>	93
<b>APPENDIX I - ABG 1975 FORMS</b>	<b>74</b>	ABG-8, <i>Construction Costs (Article 25, ABG 1975)</i>	95
ABG-1, <i>Program of Construction Projects for the U.S. Forces in Germany (Article 3.1, ABG 1975)</i>	79	ABG-9, <i>Administrative Fee (Article 26, ABG 1975)</i>	96

## TABLE OF CONTENTS

<b><u>CHAPTER</u></b>	<b><u>Pg</u></b>
<b>APPENDIX II - ABG 1975 FLOW CHARTS</b>	<b>98</b>
ABG-1	99
ABG-2	100
ABG-3	102
ABG-4	104
ABG-5 & ABG-5A	105
ABG-6	106
ABG-7 & 7B	107
ABG-8 & ABG-9	108
<b>APPENDIX III - SETTLEMENT OF DISPUTES</b>	<b>109</b>
NATO SOFA SA, Article 44 - Settlement of Disputes	110
Administrative Agreement for Settlement of Disputes	112

## I. FOREWORD

This handbook is a compendium of pertinent agreements, implementing instructions and standard forms that govern the accomplishment of construction works for and by the U.S. Forces stationed in Germany. These bilateral instruments have been jointly agreed upon and serve to maintain uniform and meaningful procedures which ensure effective and smooth performance of construction works for and by the U.S. Forces.

The overarching international agreement is the Supplementary Agreement to the NATO Status of Forces Agreement (SA NATO SOFA) that was last amended on 18 March 1993; in particular Article 49 applies to the accomplishment of construction works and Article 53 to the application of German legal and administrative procedures. Subsequently the bilateral ABG 1975 Administrative Agreement (Principles of Construction Contracting - Auftragsbauten Grundsätze) was amended on 3 November 2003 and 20 November 2008 and Implementing Instructions (IIs / RiABG) on 15 October 2009 as well as its enclosures (forms and flow charts) on 16 November 2009.

These bilateral instruments are not permanently static and hence are subject to further improvements that need to be generated primarily from practical experiences gained in the implementation of newly established provisions. Both the ABG 1975 and its Implementing Instructions are however static until renegotiated. Renegotiation is typically a lengthy and cumbersome procedure.

### English and German Abbreviations:

English Title	German Title	US / GE Abbreviations
Principles of Construction Contracting	Auftragsbauten Grundsätze 1975	ABG 1975
Protocol of Signature	Unterzeichnungsprotokoll	PoS / UP
Cover Letter	Begleitbriefe	CL / BglB
Implementing Instructions	Ausführungsrichtlinie	IIs / RiABG

NOTE: The use of brackets [ ], including titles for each article, designates descriptive text not found in the original documents/agreements. Titles were inserted to aid in locating subject matter.

## **II. NATO SOFA SA, Article 49 - Construction, Article 53 - Rights Respecting Installations and Article 53A - Special Permits and Licenses in Connection with Use of Installations**

### **NATO SOFA SA, Article 49 - CONSTRUCTION**

1. The programs of construction projects necessary to cover the requirements of a force or of a civilian component shall be transmitted to the German authorities competent for Federal building by the authorities of the force or of the civilian component.
2. Construction works shall be carried out by the German authorities competent for Federal building in accordance with German legal provisions and administrative regulations in force, and in accordance with special administrative agreements.
3. Notwithstanding the provisions of paragraph 2 of this Article, the authorities of a force or of a civilian component may carry out, in accordance with special administrative agreements existing on the entry into force of the present Agreement or which are concluded or amended thereafter, in consultation with the German authorities
  - (a) repairs and maintenance work,
  - (b) construction works which require special security measures,
  - (c) very minor construction works; and, in agreement with the German authorities
  - (d) minor construction works,
  - (e) exceptionally, construction works in other cases

with their own personnel or by placing contracts direct with contractors. In carrying out such works, the authorities of the force or of the civilian component shall respect German building and environmental regulations and shall ensure, in cooperation with the German authorities referred to in paragraph 2 of this Article, that the necessary permissions are obtained. Furthermore they shall take into consideration the principles applying in the Federal Republic regarding public construction.

4. Deleted
5. The authorities of the force or of the civilian component and the German authorities shall agree concerning the form and extent of the consultation envisaged in paragraph 3 of this Article.



## II. NATO SOFA SA, Article 49 - Construction, Article 53 - Rights Respecting Installations and Article 53A - Special Permits and Licenses in Connection with Use of Installations

6. When the work referred to in paragraph 2 of this Article is carried out on behalf of a force or a civilian component by the German authorities,
  - (a) the authorities of the force or of the civilian component may, where they consider it necessary, participate in the drafting of the plans or may furnish plans and specifications themselves;
  - (b) the method of award of the contract and, in the case of limited tender, the number and identity of the contractors to be invited, shall be agreed between the German authorities and the authorities of the force or of the civilian component.
  - (c) the contract shall be awarded only after the authorities of the force or of the civilian component have given their consent in writing;
  - (d) the authorities of the force or of the civilian component shall be permitted to participate in inspections of building work and shall have access to building plans and all relevant documents and accounts;
  - (e) the German authorities shall, unless it is otherwise agreed, confirm to contractors the satisfactory completion of major sections of the work only in agreement with the authorities of the force or of the civilian component; in particular, the German authorities shall obtain the written consent of the authorities of the force or of the civilian component before releasing the contractor from his contractual obligations;
  - (f) the sending State shall reimburse the Federal Republic in respect of
    - (i) any expenditure incumbent upon the Federal Republic under German law relating to public contracts, provided that expenditure arising from settlements out of court shall be reimbursed only if the force has consented to the settlement;
    - (ii) *ex gratia* payments made with the consent of the force;
    - (iii) expenditure, which cannot be charged to the contractor, arising from measures taken by the German authorities in cases of emergency in order to safeguard the interests of the force or of the civilian component;

## **II. NATO SOFA SA, Article 49 - Construction, Article 53 - Rights Respecting Installations and Article 53A - Special Permits and Licenses in Connection with Use of Installations**

- (g) the necessary funds shall be made available by the authorities of the force and of the civilian component in time to permit payment to be made on due dates;
- (h) the authorities of the force or of the civilian component shall be entitled, in a manner to be agreed, to audit documents relative to payments made by the competent German payment agencies;
  - (i) the sending States shall compensate the German authorities, in accordance with administrative agreements, for the special services performed by the latter in connection with the implementation of construction works (construction planning, supervision and inspection).

### **NATO SOFA SA, Article 53 - RIGHTS RESPECTING INSTALLATIONS**

1. Within accommodation made available for its exclusive use, a force or civilian component may take all the measures necessary for the satisfactory fulfillment of its defense responsibilities. German law shall apply to the use of such accommodation except as provided in the present Agreement and other international agreements, and as regards the organization, internal functioning and management of the force and its civilian component, the members thereof and their dependents, and other internal matters which have no foreseeable effect on the rights of third parties or on adjoining communities or the general public. The competent German authorities and the authorities of a force shall consult and cooperate to reconcile any differences that may arise.
2. The first sentence of paragraph 1 of this Article shall apply *mutatis mutandis* to measures taken in the air space above accommodation, provided that measures which might interfere with air traffic are taken only in coordination with the German authorities. The provisions of paragraph 7 of Article 57 of the present Agreement shall remain unaffected.

*2bis.* The use of major training areas, local training areas and local firing ranges by units brought to the Federal Republic for exercise and training purposes shall be subject to prior notification to the competent German authorities for approval. Such use shall be deemed approved unless the German authorities object within 45 days of receiving notification. However, notification alone shall suffice for units of the forces of a notifying State of up to 200 personnel which belong organically to a unit stationed in the Federal Republic, or which are intended for reinforcement of units stationed in the Federal Republic. For purposes of this Article, notice given to German authorities during scheduling conferences shall suffice. Additional agreements may be concluded.

## **II. NATO SOFA SA, Article 49 - Construction, Article 53 - Rights Respecting Installations and Article 53A - Special Permits and Licenses in Connection with Use of Installations**

*2ter.* Details of the use of major training areas, air-to-ground weapons ranges, local training areas and local firing ranges, as well as the notification and approval set out in paragraph 2bis, shall be covered by administrative agreements to be reached at the national level.

3. In carrying out the measures referred to in paragraph 1 of this Article, the force or the civilian component shall ensure that the German authorities are enabled to take, within the accommodation, such measures as are necessary to safeguard German interests.
4. The German authorities and the authorities of the force or of the civilian component shall cooperate to ensure the smooth implementation of the measures referred to in paragraphs 1, 2 and 3 of this Article. The details of such cooperation are set forth in paragraphs 5 to 7 of the Section of the Protocol of Signature referring to this Article.
5. Where accommodation is used jointly by a force or a civilian component and the German Armed Forces or German civilian agencies, the regulations required for such use shall be laid down in administrative agreements or in special agreements in which appropriate consideration shall be given to the position of the Federal Republic as receiving State as well as to the defense responsibilities of the force.
6. In order to enable a force or a civilian component satisfactorily to fulfill its defense responsibilities, the German authorities shall take appropriate measures, at the request of the force to
  - (a) establish restricted areas (Schutzbereiche);
  - (b) supervise or restrict construction, cultivation and movement in the vicinity of accommodation made available to the force for its use.

### **Re Article 53**

1. Unless otherwise provided, a force shall not be entitled to exploit for economic benefit accommodation made available for its use.

*Ibis.* Measures necessary to meet national training standards of a force shall be among the measures referred to in the first sentence of paragraph 1 of Article 53.

## **II. NATO SOFA SA, Article 49 - Construction, Article 53 - Rights Respecting Installations and Article 53A - Special Permits and Licenses in Connection with Use of Installations**

2. Exploitation by the person entitled thereto shall be restricted only to the extent necessary to achieve the purpose stated in the first sentence of paragraph 1 of Article 53.
3. The term "restricted area" (Schutzbereich) shall be interpreted in accordance with its meaning in German law. The term "appropriate measures" within the meaning of paragraph 6 of Articles 53 shall be construed to mean only such measures as can be taken by the German authorities within their legal powers.
4. Should German legislation implementing Article 53 prove insufficient to ensure that the defense responsibilities of a force can be satisfactorily fulfilled, the German authorities and the authorities of the force shall discuss the desirability or necessity of seeking amendment to such legislation.

*4bis.*

- (a) The authorities of a force shall give the competent German authorities at federal, Land and local level all reasonable assistance necessary to safeguard German interests, including access to accommodation after prior notification, so that they can fulfill their official duties. The German Federal authorities responsible for the accommodation shall assist the authorities of the force on request. In emergencies and where there is danger in delay, the authorities of the force shall make immediate access possible without prior notification. The authorities of the force shall decide in each case whether they will accompany the German authorities.
- (b) In all cases access shall be subject to considerations of military security, in particular of the inviolability of classified areas, equipment and documents.
- (c) The authorities of the force and the German authorities shall arrange access in such a way that neither the safeguarding of German interests nor military exercises which are in progress or about to start are unreasonably prejudiced.
- (d) Should there be no agreement in the cases of subparagraphs (a) to (c) of this paragraph, the competent higher authorities on both sides shall be seized of the matter.

## **II. NATO SOFA SA, Article 49 - Construction, Article 53 - Rights Respecting Installations and Article 53A - Special Permits and Licenses in Connection with Use of Installations**

5. Cooperation between the authorities of a force and the German authorities in accordance with Article 53, and, if appropriate, in conjunction with Article 53A, shall extend in particular to the following fields:
  - (a) determination of land boundaries, production of site plans and survey documents of plots of land;
  - (b) drawing up of property lists and inventories valuation of such property;
  - (c) public safety and order, including fire precautions (fire protection and assistance), disaster control, industrial safety (Arbeitsschutz), prevention of accidents and safety measures, such as those pertaining to rifle ranges, ammunition depots, fuel depots and dangerous plant;
  - (d) health and sanitation (as provided for in Article 54);
  - (e) industrial inspection;
  - (f) water, gas and electricity supply, drainage, and sewage disposal;
  - (g) property restrictions, protection of neighboring property, town and country planning, protection of monuments and sanctuaries, and environmental protection, including any identification and evaluation of sites rendered hazardous by soil contamination.
  - (h) basic preservation of land and buildings;
  - (i) water, power and heating plants, where these serve not only the force but also German agencies or the civilian population;
  - (k) use of land and buildings by the civilian population or German authorities for business, agricultural or residential purposes;
  - (l) forestry operations, hunting, shooting and fishing;
  - (m) exploitation of mineral deposits;

## **II. NATO SOFA SA, Article 49 - Construction, Article 53 - Rights Respecting Installations and Article 53A - Special Permits and Licenses in Connection with Use of Installations**

- (n) traffic precautions, as well as maintenance and cleaning of roads open to the public traffic;
  - (o) operation and maintenance of railway connections;
  - (p) telecommunications.
6. Cooperation between the authorities of a force and the Federal authorities responsible for the administration of accommodation shall be carried out in accordance with the following procedures:
- (a) The authorities of the force and the German authorities shall each designate representatives for a unit or units of accommodation. These representatives shall cooperate concerning the administration of accommodation to ensure that due consideration is given to the interests of the force and to German interests. The competencies of German technical authorities, particularly under paragraph 4bis of this Section, shall remain unaffected.
  - (b) The military commander responsible for the accommodation or other appropriate authority of the force shall give, in accordance with paragraph 4bis of this Section, the German representatives all reasonable assistance.
  - (c) Notwithstanding the provisions of subparagraphs (a) and (b) of this paragraph, the following procedures shall apply:
    - (i) The property lists and inventories of property referred to in subparagraph (b) of paragraph 5 of this Section shall normally be set up or checked at the beginning and the end of the period for which a unit of accommodation is made available to the force for its use.
    - (ii) For cooperation in the field of safety measures in respect of rifle ranges, ammunition depots and fuel depots, joint commissions may be established. Details shall be laid down in administrative agreements.
7. Where provisions of the Supplementary Agreement or special NATO regulations prescribe for certain accommodation a different procedure for cooperation in the fields referred to in paragraph 5 of this section, such provisions or regulations shall prevail.

## **II. NATO SOFA SA, Article 49 - Construction, Article 53 - Rights Respecting Installations and Article 53A - Special Permits and Licenses in Connection with Use of Installations**

### **NATO SOFA SA, Article 53A - SPECIAL PERMITS AND LICENSES IN CONNECTION WITH USE OF INSTALLATIONS**

1. Where German law applies in connection with the use of accommodation covered by Article 53 of the present Agreement, and requires that a special permit, license or other form of official permission be obtained, the German authorities shall, in cooperation with the authorities of a force and following consultation with them, submit the necessary applications and undertake the relevant administrative and legal procedures for the force.
2. The provisions of paragraph 1 of this Article shall also apply when the decision is contested by a third party, when measures or facilities are noticeable, and in cases where the proceedings are instituted *ex officio*, in particular to safeguard public safety and order, or at the instigation of a third party. In these instances German Federal authorities acting for the force shall defend the interests of the force. If a permission applied for under paragraph 1 of this Article is denied or is subsequently modified or rendered invalid in conformity with German law, the authorities of the force and the German authorities shall consult to develop alternative means of meeting the needs of the force consistent with the requirements of German law.
3. The authorities of the force shall act in strict conformity with the terms and requirements of a legally effective decision taken in accordance with paragraphs 1 and 2 of this Article. They shall cooperate closely with German authorities to ensure that this obligation is fulfilled. Such a decision shall not be subject to enforcement.

III. <u>ABG 1975 (U.S.)</u>	Protocol of Signature (PoS / UP), Cover Letter (CL / BglB) and <u>Implementing Instructions (IIs / RiABG)</u>	<u>Notes</u>
<p style="text-align: center;"><b>Administrative Agreement ABG 1975 Between the Federal Minister for Regional Planning, Building and Urban Development and the United States Forces on the implementation of Construction Works of and for the U.S. Forces stationed in the Federal Republic of Germany in accordance with Article 49 of the Supplementary Agreement to the NATO Status of Forces Agreement (SA NATO SOFA)</b></p> <p>The Federal Minister for Regional Planning, Building and Urban Development Of the Federal Republic of Germany</p> <p style="text-align: center;">and</p> <p style="text-align: center;">The United States Forces,</p> <p>intending to settle, pursuant to common principles</p> <p>On the basis of <a href="#">Article 49 of the SA NATO SOFA</a>, the details of procedures for the co-ordination of constructions works by German authorities on behalf of the U.S. Forces and Civilian Components, hereinafter referred to collectively as “Forces”, stationed in the Federal Republic of Germany, and of construction works carried out by the Forces with their own personnel or by placing contracts directly with contractors, have agreed as follows:</p>	<p style="text-align: center;"><b><u>PREFACE</u></b></p> <p>The following Implementing Instructions (IIs / RiABG) are issued in agreement with the Federal Ministry of Defence. They were developed with the participation of the competent authorities of the Federal States and, in accordance with <a href="#">Article 39</a> ABG 1975, established with the U.S. Forces stationed in the Federal Republic of Germany.</p> <p>ABG 1975, the Protocol of Signature (PoS / UP), and the supplementing Covering Letters (CL / BglB) are based on <a href="#">Article 49 Supplemental Agreement to the NATO Status of Forces Agreement (SA NATO SOFA)</a>.</p> <p>These were agreed upon and put into force as follows:</p> <ul style="list-style-type: none"> <li>- GE/U.S. Agreement of 29 September 1982 (Federal Law Gazette II of 8 October 1982 No. 37, p. 893), Circular of 30 September 1982 (MinB1Fin 1982, p. 280); effective as of 1 October 1982.</li> <li>- Amended by the GE/U.S. Agreement of 6/26 September 1988 between the Federal Minister for Regional Planning, Building and Urban Development and the U.S. Forces stationed in the Federal Republic of Germany amending the Protocol of Signature to the ABG 1975 Administrative Agreement of 29 September 1982 (Federal Law Gazette II of 18 January 1989 No. 2, p. 44); effective as of 26 September 1988.</li> <li>- Amended by GE/U.S. Agreement of 13 October 2003/3 November 2003 (Federal Law Gazette II of 6 December 2005, No. 28, p. 1242); effective as of 24 November 2003.</li> <li>- Amended by the GE/U.S. Agreement of 4 June/20 November 2008 amending the GE/U.S. Agreement of 29 September 1975 (Federal Law Gazette of 9 April 2009 No. 11 p. 332), effective as of 20 November 2008.</li> </ul> <p>The purpose of these implementing instructions is to introduce, in accordance with the above-mentioned agreement, a uniform and meaningful procedure which ensures the effective and smooth performance of construction projects for and by the U.S. Forces.</p> <p>The instructions are equally binding for the German authorities and the U.S. Forces.</p>	



<b>III.</b>	<b><u>ABG 1975 (U.S.)</u></b>	<b>Protocol of Signature (PoS / UP), Cover Letter (CL / BglB) and Implementing Instructions (IIs / RiABG)</b>	<b><u>Notes</u></b>
-------------	-------------------------------	-------------------------------------------------------------------------------------------------------------------	---------------------

<b>PART I - GENERAL</b>		
<b>◀◀</b>	<b><u>Article 1 [Terms and Definitions]</u></b>	<b>PoS - General</b>
1.1	Construction projects (projet de construction / Bauvorhaben) are items of proposed construction works.	1. Statement of Principles. The parties to the agreement recognize that the public construction procedures and policies of their respective governments may vary in many respects. They undertake to resolve any such differences and inconsistencies in a spirit of mutual cooperation.
1.2	Construction works (travaux / Baumaßnahmen) are new construction, alterations and extensions, external works, the necessary development measures, and repair and maintenance.	2. The U.S. Forces and the German authorities will not impose any restrictions with regard to the employment of U.S. Architect/Engineer firms, contractors, subcontractors and suppliers for the performance of the construction projects covered by this agreement, which would be of disadvantage for them in competition with comparable German firms.
1.3	Repair and maintenance (travail de réparation et d'entretien / Instandsetzung und Instandhaltung [Bauunterhaltung]) is work intended to maintain a facility in a proper state of preservation, or to renovate a facility without change of configuration or function.	3. The U.S. Forces will act in contractual matters through a U.S. Contracting Officer or other officials designated in writing as the authorized representatives of the U.S. Forces for such purposes.
<b>IIs - Re Article 1</b>		
1.4	New construction, alterations and extensions (constructions nouvelles, changements, agrandissements / Neu-, Um- und Erweiterungsbauten) are works which create a new facility or change an existing facility when the purpose of a facility is changed.	1.1 ABG 1975 settles the performance of the construction projects of the U.S. Forces defined in Article 1 which are financed with U.S. national funds. In individual cases, at the option of the U.S. Forces, remediation of contaminated areas, soil and groundwater and removal of unexploded ordnance may be carried out using the ABG 75 procedures, if required to complete a construction project.
1.4.1	Minor new construction, alterations, and extensions are items of construction, having a total estimated cost greater than 150,000 Euro and up to and including 375,000 Euro.	ABG 1975 may be applied to other construction projects, e.g. those financed with funds of the Federal Republic of Germany, provided that this was agreed upon beforehand between the U.S. Forces and the Federal Republic of Germany.
1.4.2	Major new construction, alterations and extensions are items of construction	The details of the mechanism (the process), by which consultation within the meaning of Article 1.10 ABG 1975 is carried out in specific

III. <u>ABG 1975 (U.S.)</u>	<u>Protocol of Signature (PoS / UP), Cover Letter (CL / BglB) and Implementing Instructions (IIs / RiABG)</u>	<u>Notes</u>
<p>having a total estimated cost greater than 375,000 Euro.</p>	<p>cases, are found in Article 27, paragraphs <a href="#">2</a> and <a href="#">6</a> of these Implementing Instructions.</p>	
<p>1.4.3 Very minor new construction, alterations and extensions are items of construction having a total estimated cost up to and including 150,000 Euro.</p>	<p>1.2 Definitions</p>	
<p>1.5 Indirect procedure (procédure indirect / Regel- oder Auftragsbauverfahren) means the planning, execution and administration of construction works by the German authorities on behalf of the Forces. Such planning and execution, that is to say, supervision and carrying out of the construction works, may be accomplished either by the German authorities using their own personnel or by contract between them and civilian construction, engineering or architectural firms and specialists.</p>	<p>1.2.1 Pre-Concept Design Submission Kostenvoranmeldung-Bau (KVM-Bau)). The contents and scope of the KVM- Bau are detailed in <a href="#">Article 7.1.2</a> ABG 1975. By agreement with the U.S. Forces further details may be promulgated by decree (Erlass).</p> <p>1.2.2 Concept Design Submission (Hauhaltsunterlage-Bau (HU-Bau)). The contents and scope of the HU- Bau are detailed in <a href="#">Article 7.1.3</a> ABG 1975. By agreement with the U.S. Forces further details may be promulgated by decree (Erlass).</p> <p>1.2.3 Final Design Submission (Ausführungsunterlage- Bau (AFU-Bau)). The contents and scope of the final design submission (AFU-Bau) are detailed in <a href="#">Article 7.1.4</a> ABG 1975. By agreement with the U.S. Forces further details may be promulgated by decree (Erlass).</p>	
<p>1.6 Direct procedure (procédure directe / Truppenbauverfahren) means the planning, execution and administration of construction works by the Forces using either their own personnel or labour employed by them, or through contracts which are made directly by the Forces.</p>	<p>1.2.4 Building authority (Bauamt) / Agency Responsible for Technical Oversight (Fachaufsicht führende Ebene - FfE).</p> <p>“Building authority” is the term for the state level authority responsible for construction execution.</p> <p>“Agency Responsible for Technical Oversight” is the term for the state level authority responsible for the technical and functional oversight of construction execution; for example Regional Finance Office (OFD) Frankfurt, OFD Koblenz - Federal Construction Division (GBB), State Construction Directorate (LBD) co-located with Autobahndirektion Nordbayern.</p>	
<p>1.7 Working days (jours ouvrables / Arbeitstage) are calendar days excluding Saturdays, Sundays and German public holidays.</p>		
<p>1.8 Term contracts (contrats á terme / Zeitverträge) are main contracts for a specified period for the execution of</p>	<p>1.2.5 Workdays (Werktage). Workdays (Werktage) are all calendar days except Sundays and German public holidays.</p>	

III. <u>ABG 1975 (U.S.)</u>	Protocol of Signature (PoS / UP), Cover Letter (CL / BglB) and <u>Implementing Instructions (IIs / RiABG)</u>	<u>Notes</u>
<p>regularly recurring repair and maintenance work as well as minor new construction, alterations and extensions. Such contracts are put out to tender and concluded on the basis of a tendered percentage, increase or decrease, on prices listed in schedules of specifications and rates. Individual orders are placed, as required, on the basis of these main contracts.</p> <p>1.9 A consultant (travailleur indépendant / freiberuflich Tätiger) is an architect; interior, garden and landscape designer; engineer or other expert for technical building matters called in by the German authorities.</p> <p>1.10 For the purposes of this Agreement:</p> <p>1.10.1 the term "in consultation with the German authorities" means that the Forces shall inform the German authorities of its intentions and shall take note of and consider comments of the German authorities; and</p> <p>1.10.2 the term "in agreement with" means that the Forces and the German authorities shall concur.</p>		
<p>◀◀ <b><u>Article 2 [Direct vs. Indirect Procedures]</u></b></p> <p>2.1 Construction works shall be carried out by the German authorities responsible for Federal construction works (indirect procedure).</p> <p>2.2 Notwithstanding the provisions of Article 2.1, the Forces may execute the</p>	<p style="text-align: center;"><b>IIs - Re Article 2</b></p> <p>2.1 The responsible German authorities within the meaning of Article 2.1, ABG 1975 are, according to the Finanzverwaltungsgesetz and the administrative agreements concluded thereto, the authorities of the Bauverwaltungen of the Federal States designated therein.</p> <p>2.2 The supreme technical agencies are the Federal Ministry of Transport, Building and Urban Affairs and the Federal Ministry of Defence. The</p>	

III. <u>ABG 1975 (U.S.)</u>	<b>Protocol of Signature (PoS / UP), Cover Letter (CL / BglB) and Implementing Instructions (IIs / RiABG)</b>	<u>Notes</u>
<p>construction works themselves (direct procedure) in the special cases defined in <a href="#">Article 27</a> of this Agreement</p>	<p>U.S. Forces and the German authorities will be informed on the specific competencies together with the results of program coordination (see <a href="#">Article 3</a>, ABG 1975).</p> <p>2.3 The organizational authority of the Federal Republic of Germany to arrange for the performance of particular functions by a centralized agency will not be affected hereby.</p>	
<p><b>◀◀ <u>Article 3 [Program Coordination]</u></b></p> <p>3.1 Programs of construction projects necessary to meet the requirements of the Forces shall be forwarded and coordinated periodically, but at least once a year, between the authorities of the Forces and the Federal Minister for Transport, Building and Housing and the Federal Minister of Defense.</p> <p>For the purpose of program coordination, the German authorities shall be informed of each construction project costing more than 150,000 Euro and shall be given a list by location of those costing no more than 150,000 Euro each. Special mention shall be made of those construction projects costing over 150,000 Euro which the Forces wish to implement under the direct procedure.</p> <p>3.2 Construction projects costing no more than 150,000 Euro each and carried out by the Forces under direct procedures are exempt from program coordination.</p> <p>Notwithstanding the above, where there is indication that permissions or notifications under public law are necessary for construction projects,</p>	<p style="text-align: center;"><b>PoS - re Article 3</b></p> <p>1. Due to the procedure set forth by law whereby the required funds are authorized and appropriated, the U.S. Forces are not in a position to identify all construction projects in advance. The U.S. Forces are, however, in a position to and will report the construction projects approved by the U.S. Congress as soon as they are known and identified. In exceptional cases of special urgency, it will be possible to make program coordination by telephone.</p> <p>2. The regulations of the U.S. Forces stipulate that funds are made available on a regional basis for repair and maintenance measures, as well as for minor new construction, alterations and extensions without being identified with particular construction projects. These amounts will be specified in totals, by community, corresponding to the organization of the Forces.</p> <p>3. The procedures for the accomplishment of the individual construction projects under the indirect procedure (<a href="#">Part II ABG 1975</a>) and under the direct procedure (<a href="#">Part III ABG 1975</a>) are not affected hereby.</p> <p style="text-align: center;"><b>IIs - Re Article 3</b></p> <p>3.1 Intent and purpose of program coordination is to obtain information as early as possible on the construction plans of the U.S. Forces and to coordinate these with other construction projects in order to ensure a smooth accomplishment of the individual projects by making the best use possible of the German design and construction capacities.</p>	

III. <u>ABG 1975 (U.S.)</u>	<u>Protocol of Signature (PoS / UP), Cover Letter (CL / BglB) and Implementing Instructions (IIs / RiABG)</u>	<u>Notes</u>
<p>these projects shall be included in the program coordination for the specific purpose of ascertaining the necessity of obtaining these permissions or meeting notification requirements, or shall otherwise be made known at short notice.</p> <p>In cases where clarification is necessary, the German authorities shall provide, free of charge, general advice and assistance at the request of the Forces.</p> <p>3.3 When ascertaining costs for Article 3.1 or 3.2, services and supplies to be provided by the Forces shall be included in the total construction cost at the price which normally would have been paid to a contractor.</p>	<p>3.2 The Federal Ministry of Transport, Building, and Urban Affairs will be the responsible agency for the entire program coordination. Assistance on the German side will be provided by the Federal Ministry of Defence and the responsible supreme Land authorities. The Bundesanstalt für Immobilienaufgaben (Federal Institute for Real Estate) will be furnished information.</p> <p>3.3 Enclosure 2 [Appendix II of this handbook] to these Implementing Instructions contains a schematic representation of the sequence of program coordination. The following has been determined in addition:</p> <p>3.3.1 Program coordination which shall be conducted periodically, at least once a year, as a rule takes place immediately after the budgets of the U.S. Forces have been published. The U.S. Forces will transmit their construction program on Form ABG 1. The programs will include also those projects of the old programs which have not yet been accomplished, i.e. projects for which Forms ABG 2 or 3 have not yet been issued.</p> <p>In cases falling under Article 3.2 ABG 1975 where permissions are or may be required or notifications must be made, the construction projects shall be listed as a separate category of work on the ABG 1 program coordination document or made known otherwise at short notice. At the request of the U.S. Forces an early meeting will be held with the responsible German authority (e.g. Oberfinanzdirektion) to enable the German authorities to give advice and assistance in connection with obtaining permissions or meeting notification requirements for specific projects. A splitting of construction works in the ABG 1 program coordination document should be avoided when the construction project will be accomplished in one phase.</p> <p>3.3.2 Upon receipt of the ABG 1 program coordination documents, the German authorities will check whether public interests are affected and furnish the Federal Ministry of Transport, Building, and Urban Affairs their comments, if possible within a period of 4 weeks. At the same time, information is furnished on requests provided for in <a href="#">Article 29</a>, ABG 1975. If the U.S. Forces determine during further</p>	

III. <u>ABG 1975 (U.S.)</u>	<b>Protocol of Signature (PoS / UP), Cover Letter (CL / BglB) and Implementing Instructions (IIs / RiABG)</b>	<u>Notes</u>
	<p>processing of construction projects that any permissions are required in accordance with public law for such projects that were not also included in the previous ABG 1 program coordination document, the German authorities will be notified.</p> <p>3.3.3 The Federal Ministry of Transport, Building, and Urban Affairs will consolidate all comments, will furnish the U.S. Forces the results, and will inform the other participating German authorities thereof.</p> <p>3.3.4 The telephonic program coordination mentioned in the Protocol of Signature [PoS] (UP) re Article 3 No. 1 will be confirmed in writing by the Federal Ministry of Transport, Building, and Urban Affairs. Notwithstanding Article 3.1 PoS [UP], ABG 1975 in urgent cases program coordination may also be made by other means such as electronically.</p> <p>3.3.5 Projects of the U.S. Army and the U.S. Navy will be announced by U.S. Army Installation Management Command, Europe Region (IMCOM-Europe), projects of the U.S. Air Force will be announced by Headquarters, United States Air Force, Europe (HQ USAFE). Notification is also possible by way of lists prepared by computer.</p> <p>3.3.6 Where a special permit, license or other form of official permission must be obtained under public law, the German authorities shall, in cooperation with the authorities of the U.S. Forces and following consultation with them, submit the necessary applications and undertake the relevant administrative and legal procedures (Verfahrens- und Prozess- standschaft). If required, both sides will appoint a competent contact person for the coordination of each procedure.</p>	

III.	<u>ABG 1975 (U.S.)</u>	Protocol of Signature (PoS / UP), Cover Letter (CL / BglB) and <u>Implementing Instructions (IIs / RiABG)</u>	<u>Notes</u>
------	------------------------	------------------------------------------------------------------------------------------------------------------	--------------

<b>PART II - EXECUTION OF CONSTRUCTION WORKS THROUGH THE GERMAN AUTHORITIES (INDIRECT PROCEDURE)</b>		
<b>SECTION A - EXECUTION</b>		
	<b><u>Article 4 [Adherence to Legal and Administrative Regulations]</u></b>	<b>PoS - re Article 4.1</b>
4.1	Construction works shall be executed by the German authorities in their own name and on their own responsibility and in accordance with German laws and administrative regulations in force for Federal building. The special procedural rules set down in <a href="#">Article 5.1</a> shall apply to the award of construction contracts.	The U.S. Forces can demand that in contracts for construction services which are concluded by the German authorities
4.2	If any regulation of the Forces regarding public safety and order lays down higher standards than the German regulations, the Forces' regulations shall be observed if they so request. The Forces accept responsibility arising directly from the application of such standards. The Forces shall attach to their request the technical details, which are to be observed. The request must be made sufficiently early to allow cost calculations to be made.	1. it will be agreed that the contractor will provide securities
4.3	As far as projects concern the organization, internal functioning and management of the Force and its civilian component, the members thereof and their dependents, or as internal matters have no foreseeable effect on the rights of third parties or on adjoining communities or the general public ( <a href="#">Art. 53, para. 1, sentence 2, SA NATO</a> )	1.1 for performance of the services including accounting as per contract (contract performance security), as a rule, up to 5 % of the contract amount including all supplements. The performance security may be increased at the same percentage rate when the contract amount is increased based on supplementary arrangements unless the increase is less than 10 % of the contract amount;
		1.2 for the warranty (warranty security), as a rule, 3 % but no more than 5 % of the contract amount, including all supplements. The security ends with the expiration of the period of prescription for the warranty and after the demands filed until that date have been satisfied. If the U.S. Forces demand a higher percentage of guarantee than provide for herein, the German authorities will consider any such request on a special case basis, and if justified by the documented reasons furnished, will approve such deviation.
		2. liquidated damages are agreed upon if the contractor is late completing the construction work.
		Such damages will be at the rate of 1/10 of 1 % of the final construction contract amount for each workday <sup>*)</sup> of delay, but in no event to exceed a total of 10 % of the final contract amount. <i>*) = Calendar days excluding Sundays and German public holidays.</i>
		<b>PoS - re Article 4.4</b>

III. <u>ABG 1975 (U.S.)</u>	Protocol of Signature (PoS / UP), Cover Letter (CL / BglB) and <u>Implementing Instructions (IIs / RiABG)</u>	<u>Notes</u>
<p><a href="#">SOFA</a>), the Forces may insist that, in individual cases, their own standards be applied.</p> <p>4.4 Measures changing or affecting the scope, quality or cost of construction works from that specified by the Forces shall require the prior consent of the Forces.</p> <p>4.5 If the Forces participate in drafting the plans or place them at the disposal of the German authorities, the German authorities have the right to review such plans and specifications to ensure the observance of German laws and regulations.</p>	<p>The terms of Article 4.4 shall apply equally to measures that require extensions of time for completion of the construction contract.</p> <p style="text-align: center;"><b>PoS - re Article 4.5</b></p> <ol style="list-style-type: none"> <li>1. The participation of the Forces in the accomplishment of the construction measures mentioned in Article 4.5 and provided for in <a href="#">Article 49 (6) (a) SA NATO SOFA</a> will not affect the obligation resulting for the German authorities from the principle in Article 4.1.</li> <li>2. Insofar as the U.S. Forces perform an essential portion of the administrative tasks for term contracts, this will be given consideration in compensation (<a href="#">Article 23.1.2</a>).</li> </ol> <p style="text-align: center;"><b>CL - re Article 4.2</b></p> <p>Whenever agreement cannot be reached with responsible local authorities on the application of particular regulations, the U.S. Forces may establish direct contact with the highest Federal authorities responsible.</p> <p style="text-align: center;"><b>IIs - Re Article 4</b></p> <ol style="list-style-type: none"> <li>4.1.1 Supporting documentation pertaining to the application of U.S. standards in accordance with Articles 4.2 or 4.3 ABG 1975 shall be submitted by the U.S. Forces, if possible, together with the request for the first service provided for in <a href="#">Article 7</a> ABG 1975, however no later than with the approval of the concept design submission (HU-Bau). If a HU-Bau is not required the request shall be submitted with the request for the first of the following services under <a href="#">Article 7</a> ABG 1975. Insofar as additional design work becomes required due to the belated transmission of the request, compensation herefore shall be paid within the framework of <a href="#">Article 20.2</a> ABG 1975.</li> <li>4.1.2 If the U.S. Forces wish to apply their own standards in the field of public safety and order in individual cases under Article 4.2 ABG 1975, the following shall apply: The U.S. Forces must supply</li> </ol>	



III. <u>ABG 1975 (U.S.)</u>	Protocol of Signature (PoS / UP), Cover Letter (CL / BglB) and <u>Implementing Instructions (IIs / RiABG)</u>	<u>Notes</u>
	<p>proof that their standards are more stringent than those stipulated by German law, and notify the German authorities on the outcome of their examination. The German authorities shall inform the U.S. Forces of their position in writing.</p> <p>4.1.3 If the U.S. Forces insist on the application of their own standards in accordance with Article 4.3 ABG 1975, they must supply proof in writing that the conditions for application of the SSF standards are met. If in the opinion of the German authorities the conditions do not exist they must consult the agencies of the U.S. Forces prior to providing written comments in order to clarify any possible differences of opinion. The procedure according to <a href="#">Article 40.2</a> ABG 1975 remains unaffected.</p> <p>4.2 In general, changes during construction execution are to be avoided.</p> <p>4.2.1 If changes cannot be avoided the U.S. Forces, the German authorities, and, if applicable, also the contractors will coordinate:</p> <ul style="list-style-type: none"> <li>- the type and scope of the change</li> <li>- any increases/decreases in cost resulting from the change</li> <li>- any changes in the execution deadlines.</li> </ul> <p>4.2.2 The realization of changes under 4.2.1 of these Implementing Instructions always require a change request (ABG 5 Part I or 5 A) and an order of the U.S. Forces by use of Form ABG 5 Part II. Under Part I of the Form ABG 5, the German authorities shall include the rationale and urgency for each change and the impact if a change was not approved by the U.S. Forces. If the German authorities are not yet in a position to provide a request for change using Form ABG 5, Part 1, they will provide advance notification of the change. The U.S. Forces will respond to such advance notification as quickly as possible in order to avoid undue delay in construction work. Details regarding the procedure are shown in enclosure 2 [Appendix II of this handbook] to these implementing instructions.</p>	

III. <u>ABG 1975 (U.S.)</u>	Protocol of Signature (PoS / UP), Cover Letter (CL / BglB) and <u>Implementing Instructions (IIs / RiABG)</u>	<u>Notes</u>
	<p>4.2.3 Changes shall be indicated on the approved drawings.</p> <p>4.2.4 Necessary insignificant changes required during construction execution (so-called petty cases) may be made by the German authorities also without the prior approval by the U.S. Forces whenever</p> <ul style="list-style-type: none"> <li>- a deficiency noted during construction execution must be corrected immediately, and</li> <li>- no extra costs arise as compared to the agreed upon amounts (<a href="#">Article 12.3</a> ABG 1975), and</li> <li>- the planning concept and the type and scope of construction execution remain unchanged.</li> </ul> <p>For all changes of this nature, the Forces shall be furnished a written justification without delay.</p> <p>4.3 If, in accordance with <a href="#">Article 49 (6) (a) SA NATO SOFA</a>, the U.S. Forces wish to provide plans and specifications for a construction project which shall be accomplished in accordance with <a href="#">Part II ABG 1975</a> under the indirect procedure, such documents may be worked out by personnel of the U.S. Forces or by an A/E firm directly tasked by the U.S. Forces.</p> <p>When the U.S. Forces furnish the above-mentioned documents in the German and English languages, translation fees will not be charged. The observance of German laws and regulations (<a href="#">Article 4.5</a> ABG 1975,) during the preparation of these documents is ensured inasmuch as the U.S. Forces consult already in this phase the German authorities as provided in <a href="#">Article 7.1.1</a> ABG 1975. Necessary changes and additions to the documents based on prior inquiries of the German technical authorities may be made, at the request of the U.S. Forces, either by the U.S. Forces themselves or by the German authorities. The review of the static proofing shall be arranged for in every case by the German authorities.</p> <p>The U.S. Forces shall forward the completed documents to the agency responsible for technical supervision together with their request on Form ABG 3.</p>	

III. <u>ABG 1975 (U.S.)</u>	<u>Protocol of Signature (PoS / UP), Cover Letter (CL / BglB) and Implementing Instructions (IIs / RiABG)</u>	<u>Notes</u>
	4.4 Matters concerning tree-cutting will be settled separately by circular of the Federal Ministry of Finance.	
<p> <b>Article 5 [Solicitation and Award Procedures]</b></p> <p>5.1 The procedures for the award of contracts for construction works, and for deliveries and services connected with construction works, shall be based solely upon Part (Abschnitt) 1 of the Contracting Regulations for the Award of Construction Works (Vergabe- und Vertragsordnung für Bauleistungen) (VOB/A) and Part (Abschnitt) 1 of the Contracting Regulations for Services Except Construction Services (Verdingungsordnung für Leistungen - ausgenommen Bauleistungen) (VOL/A), and the administrative regulations in force for Federal building. In accordance with section 100(2)(a) of the Act against Restraints of Competition (Gesetz gegen Wettbewerbsbeschränkungen - GWB), the provisions of Part (Abschnitt) IV of the GWB, Parts (Abschnitte) 2 to 4 of the VOB/A, Parts (Abschnitte) 2 to 4 of the VOL/A and the Contracting Regulations for Consultant Services (Verdingungsordnung für freiberufliche Leistungen- VOF) shall not apply.</p> <p>5.1.1 The method of invitation to tender for construction works shall be agreed between the German authorities and the Forces. In conformity with the contracting regulations, [referred to in</p>	<p style="text-align: center;"><b>PoS - re Article 5.1</b></p> <ol style="list-style-type: none"> <li>1. The tenders shall normally be requested to be expressed in DM.</li> <li>2. Clauses allowing additional compensation for escalation of costs require the prior approval of the U.S. Forces.</li> <li>3. The acceptance of a tender which, according to the guidelines of the Federal Republic of Germany concerning the consideration of preferred tenderers in government contracting, is slightly higher than the most economical and/or acceptable responsive tender must be approved first in writing by the U.S. Contracting Officer. The most economical and/or acceptable responsive tender of the non-preferred tenderer shall be submitted to the U.S. Contracting Officer together with the recommended preferred tenderer.</li> </ol> <p style="text-align: center;"><b>IIs - Re Article 5</b></p> <p>5.1 Regulations for awarding contracts for Federal building are in particular</p> <ul style="list-style-type: none"> <li>- Vergabe- und Vertragsordnung für Bauleistungen –VOB- Teil A, Abschnitt 1 / (Award and Contract Procedure for Construction Services- VOB- Part A, Section 1)</li> <li>- Verdingungsordnung für Leistungen- VOL – Teil A, Abschnitt 1/ (Contract Procedure for Services – Part A, Section 1)</li> <li>- Vergabe- und Vertragshandbuch für die Baumassnahmen des Bundes (VHB) / Manual for awarding contracts for construction work of the Federal Government.</li> <li>- The contract procedure for free-lance consultants’ services (VOF) is not applicable.</li> </ul>	

III. <u>ABG 1975 (U.S.)</u>	<u>Protocol of Signature (PoS / UP), Cover Letter (CL / BglB) and Implementing Instructions (IIs / RiABG)</u>	<u>Notes</u>
<p>Article 5.1 above] and for technical or economic reasons including reasons related to the special budgetary restraints of the Forces, the Forces may request that multi-trade contracts be let. In individual cases, this may result in the use of general contractors. Each request shall be made and explained in writing.</p> <p>5.1.2 If requested by the Forces in cases of limited invitations to tender (beschränkte Ausschreibung) or negotiated award procedures [e.g. single source awards] (freihändige Vergabe), the number and names of proposed tenderers for each tender action are to be agreed between the German authorities and the Forces. The Forces may request that deletions, additions or substitutions be made. The German authorities shall check the capacity and expertise as well as the financial reliability and technical capabilities of all firms nominated by German authorities and, if requested, those nominated by the Forces. The German authorities shall conform with the regulations for awarding contracts for Federal building in accordance with Article 5.1 above. The Forces' recommendations shall be complied with in so far as they do not contravene these regulations. If they do contravene these regulations, the German authorities shall inform the Forces in writing giving the reasons for their objections to the Forces' recommendations.</p> <p>5.1.3 Upon the request of the Forces, invitations to tender shall, in addition to</p>	<p>5.2 The German authority addressed in this article is the responsible Bauamt. The authority of the U.S. Forces is the Chief of the responsible construction agency or his representative.</p> <p>5.3 To ensure the timely notification required by Article 5.2 ABG 1975, the U.S. Forces shall be furnished the "invitation to tender" at the same time as the proposed tenderers.</p> <p>5.4 The method of invitation to tender is in principle governed by VOB/A Article 3.</p> <p>5.5 If, in exceptional cases, the U.S. Forces have special requests in regard to the method of invitation to tender they shall inform hereof on Form ABG 3 under "Remarks" at the same time they request services as provided in <a href="#">Article 7.1.5</a> ABG 1975.</p> <p>5.6 In cases involving limited invitations to tender or negotiated award procedures (e.g. single source awards); the German authorities shall furnish the U.S. Forces timely information on the number and names of the proposed tenderers. The bidder's list, to be dealt with confidentially, will be submitted only to persons designated by the U.S. Forces.</p> <p>5.7 After the opening of the tenders, the responsible U.S. agency may obtain advance telephonic information regarding the names of the tenderers and the final amounts of the tenders, as well as the number of proposed changes and alternative tenders.</p> <p>5.8 Notwithstanding Article 5.1.2 of PoS [UP] ABG 1975 the German authorities will inform the U.S. Forces prior to solicitation where clauses pertaining to escalation of costs are included in the bidding/contract package. Normally cost escalation clauses for U.S. projects will not be included in bidding/contract packages.</p> <p>5.9 In justified individual cases the U.S. Forces may demand the solicitation of construction services by way of deductive items (Zusätzliche Leistungsabschnitte). In such cases, the basic items and clearly defined deductive items will be laid down in the description of work. All items of work (basic items and each deductive item) must</p>	

III. <u>ABG 1975 (U.S.)</u>	<b>Protocol of Signature (PoS / UP), Cover Letter (CL / BglB) and Implementing Instructions (IIs / RiABG)</b>	<u>Notes</u>
<p>the obligatory publication in the Federal Republic of Germany, also be advertised in other countries.</p> <p>5.2. The Forces shall be informed in good time of the date and place of opening of the tenders. They may send a representative to participate in the opening.</p> <p>5.3. The Forces may reject, through the German authorities, any tender in so far as this rejection is not in conflict with German law.</p>	<p>be self-contained and independently functional. The sequence of the designated deductive items will be listed in the description of work; this sequence is binding for the bid evaluation and contract award. The estimated grand total of the basic items and deductive items must not exceed the amount of "available funds" communicated by the U.S. Forces pursuant to <a href="#">Article 12.2</a> of these Implementing Instructions. The deductive items should not account for more than 15 percent of the basic items and will be obligated within the amount of "available funds" and in the sequence set out in the solicitation. Furthermore, the provisions of <a href="#">Article 20.3</a> of these Implementing Instructions apply.</p>	
<p> <b><u>Article 6 [Exemption from Payment of Taxes and Duties]</u></b></p> <p>Deliveries and services for the German authorities in connection with construction works carried out for the Forces shall be regarded as deliveries and supplies to the Forces and shall be exempt from taxes and duties in accordance with Article 67 of the SA NATO SOFA or other agreements. Where the Forces are entitled to exemption from tax or duty the amount of such tax or duty shall be excluded from all calculations, tenders, invoices and other accounting documents.</p>	<p style="text-align: center;"><b>IIs - Re Article 6</b></p> <p>6.1 The exemption from taxes and duties includes above all exemptions from the turnover tax in accordance with Article 67 SA NATO SOFA. (Details: FMOF-Decree of 22 December 2004 - IV A6 - p. 7492 - 13/04 effective from 1 January 2005 - printed in the Bundessteuerblatt [Federal Tax Gazette] I 2005, p. 75). The regulations governing the exemption shall also be applied if the German authorities, based on a request presented by the U.S. Forces on Form ABG 3, carry out procurement actions or construction works for the U.S. Forces (indirect procedure under Part II ABG 1975). In these cases, the German authorities will issue the contractor a certificate in accordance with the sample attached to the above-mentioned decree.</p> <p>6.2 The following note shall be included in the tender documents: "Deliveries and other services for the U.S. Forces shall be exempt from turnover tax in accordance with Article 67 Para. 3 Supplementary Agreement to the NATO Status of Forces Agreement. As proof for the tax-exemption of these deliveries and other services, the contractor will be issued a certificate by the Bauamt for presentation to the Tax Office."</p> <p>6.3 The invoices and final invoices of the contractor shall contain the following confirmation of the contractor:</p>	

III. <u>ABG 1975 (U.S.)</u>	Protocol of Signature (PoS / UP), Cover Letter (CL / BglB) and <u>Implementing Instructions (IIs / RiABG)</u>	<u>Notes</u>
	"The invoice amount does not contain any turnover tax."	

<b>III.</b>	<b><u>ABG 1975 (U.S.)</u></b>	<b>Protocol of Signature (PoS / UP), Cover Letter (CL / BglB) and Implementing Instructions (IIs / RiABG)</b>	<b><u>Notes</u></b>
-------------	-------------------------------	-------------------------------------------------------------------------------------------------------------------	---------------------

<b>SECTION B - RESPONSIBILITIES OF THE GERMAN AUTHORITIES AND OF THE U.S. FORCES</b>		
<p><b>◀◀</b></p> <p style="text-align: center;"><b><u>Article 7</u></b></p> <p><b><u>[Tasks of the German authorities]</u></b></p> <p>7.1 In the execution of construction works for the Forces, the German authorities shall be responsible for the following tasks:</p> <p>7.1.1 Providing general advice to the Forces on all technical and other matters connected with the construction works;</p> <p>7.1.2 Preparation and submission of a “Kostenvoranmeldung - Bau.” This shall consist of an informal explanatory report, a rough cost estimate, a general location plan (town plan or survey map with the location of the site marked on it), and a building expert’s technical report as to the suitability of the site. The German authorities shall forward a copy of the “Kostenvoranmeldung - Bau” to the Forces for review;</p> <p>7.1.3 After Forces approval of the “Kostenvoranmeldung - Bau”</p> <p>preparation and submission of the “Haushaltsunterlage - Bau”, consisting of plans, an explanatory report, cost calculation, quantity calculation, and the building expert’s technical report in accordance with Article 7.1.2 above.</p> <p>The German authorities shall forward a copy of the “Haushaltsunterlage - Bau” to the Forces for review;</p>	<p style="text-align: center;"><b>PoS - re Articles 7.1.2 through 7.1.6</b></p> <p>The German authorities will simultaneously furnish English and German language versions of all specifications and drawings submitted for review, unless otherwise waived in ABG Form 3.</p> <p style="text-align: center;"><b>PoS - re Article 7.1.9</b></p> <p>The reproducible as-built drawings mentioned in this article shall be made available to the Forces in the German and English languages no later than 90 calendar days after the date of the turnover of the completed construction works. The documents needed to put into service technical facilities as well as parts lists shall, however, be provided at the time of the turnover. This applies also in the event of a phased turnover.</p> <p style="text-align: center;"><b>CL - re Article 7.1.4</b></p> <p>According to Article 7.3 the U.S. Forces may, in individual cases, waive examination of the Ausführungsunterlage - Bau or parts thereof.</p> <p style="text-align: center;"><b>IIs - Re Article 7</b></p> <p>7.1 No later than 1 month upon receipt of the request (ABG 3), the Bauamt shall determine, in coordination with the responsible agency of the U.S. Forces, the course of the requested services and shall furnish the U.S. Forces a time schedule hereon.</p> <p>7.2 The building expert’s technical report concerning the suitability of the site addressed in Article 7.1.2 ABG 1975 may include the impacts of contaminated areas and flood protection if applicable and if agreed to by the U.S. Forces. With the approvals provided for in Articles 7.1.3 thru 7.1.6 ABG 1975, the U.S. Forces agree to the services rendered by the German authorities and assure of the fulfilment of the financial obligations entered into when contract was awarded. The responsibility for accuracy of technical execution is not contained in these approvals. <a href="#">Article 4</a> ABG 1975 is not affected hereby.</p>	

III. <u>ABG 1975 (U.S.)</u>	<u>Protocol of Signature (PoS / UP), Cover Letter (CL / BglB) and Implementing Instructions (IIs / RiABG)</u>	<u>Notes</u>
<p>7.1.4 After the Forces have agreed, in principle to the “Haushaltsunterlage - Bau”;</p> <p>complete preparation of the “Ausführungsunterlage - Bau” consisting of design drawings, working drawings, specifications (together with bills of quantity), approved structural analyses, together with calculations and relevant drawings showing the stability of the design, proof of thermal and sound insulation and fire protection, and other calculations.</p> <p>The German authorities shall forward a copy of the “Ausführungsunterlage - Bau” for review and approval by the Forces.</p> <p>7.1.5 After the forces have approved the “Ausführungsunterlage - Bau” and concurred in the tendering arrangement as provided for in <a href="#">Article 5</a>:</p> <p>the invitation, opening and evaluation of tenders and recommendation for contract award. The recommendation for contract award shall be accompanied by:</p> <p>7.1.5.1 a record of the results of the tender opening summarizing the tenders received;</p> <p>7.1.5.2 a comparative analysis of the principal unit rates of the three lowest valid tenders;</p>	<p>7.3.1 If considered necessary by the German authorities, following consultation with the U.S. Forces, as-built drawings will be provided as part of preparing the preliminary design (KVM-Bau) submission described in Article 7.1.2 ABG 1975. The responsibility for updating as-built drawings falls on the agency that carried out any facility modifications: the Bauamt for indirect projects and the U.S. Forces for direct projects. In cases where the designation of the responsible agency is unclear, the U.S. Forces will be responsible.</p> <p>7.3.2 One copy of the specifications mentioned in Article 7.1.4 ABG 1975 shall be provided with estimated prices.</p> <p>7.3.3 The preliminary design documents (KVM-Bau), concept design documents (HU-Bau), and final design documents (AFU-Bau) shall be provided in a common German digitized format for new construction, alterations and extensions if requested by the U.S. Forces and coordinated with the German authorities. Supplementing Article 7.3.1 of these Implementing Instructions the U.S. Forces may request the preparation of supporting design documentation (e.g. as-built documentation) in a digitized format, if not otherwise available. The data shall only be used for its authorized purpose. The CADD format of the drawings, including the specific symbology and level structure, shall be agreed upon prior to the start of design. The same applies for maintenance and repair work if specifically requested by the U.S. Forces. See <a href="#">Article 16.4.4</a> of these Implementing Instructions for payment procedures.</p> <p>7.4 The submission of the AFU-Bau under Article 7.1.4 ABG 1975 may be made in sections provided that the U.S. Forces have agreed hereto.</p> <p>7.5 The offer of the tenderer addressed in Article 7.1.5.3 ABG 1975, as well as the documents mentioned in Article 7.1.5.4 ABG 1975 shall be mailed as certified copies or photostats.</p> <p>7.6 Matters related to ongoing construction projects may be dealt with in monthly GE/U.S. meetings. Within 4 weeks after the date for construction commencement has been established, a construction time</p>	



III. <u>ABG 1975 (U.S.)</u>	<u>Protocol of Signature (PoS / UP), Cover Letter (CL / BglB) and Implementing Instructions (IIs / RiABG)</u>	<u>Notes</u>
<p>7.1.5.3 the name of the recommended tenderer with a copy of his detailed offer;</p> <p>7.1.5.4 copies of the working drawings and specifications (including details of dimensions and quantities);</p> <p>7.1.5.5 in the case of invitation to tender for term contracts:</p> <p>7.1.5.5.1 a comparative analysis of the percentage additions to, or deductions from, basic schedules rates and other particulars quoted by each tenderer;</p> <p>7.1.5.5.2 copies of the contract documents.</p> <p>7.1.6 After the Forces have concurred in writing, the award of contracts and transmission to the Forces of the following documents:</p> <p>7.1.6.1 copies of contracts; and</p> <p>7.1.6.2 reproducible copies of working drawings and specifications incorporating revisions, when it has been necessary to amend the approved “Ausführungsunterlage - Bau” during the tender period.</p> <p>7.1.7 Supervision and coordination of the execution of the contracts; also contract administration including accounting, making payments (payments on account and final payments), taking the necessary measurements, making the necessary calculations, and, on request, submitting monthly progress reports.</p>	<p>schedule shall be submitted to the U.S. Forces. In the event of any significant changes in established dates, the monthly construction progress reports required by Article 7.1.7 ABG 1975 shall be supplemented by a revised construction time schedule which reflects the most recent status.</p> <p>7.7.1 The extent of the as-built drawings (Baubestandszeichnungen) (Article 7.1.9 ABG 1975) shall be in accordance with the RBBau (Part H). For new construction, alterations and extensions the U.S. Forces shall be furnished 1 printed version of the as-built drawings and 1 digital version in a common German commercial CADD format if the design has been carried out using CADD.</p> <p>In relation to Article 7.1.9 ABG 1975 in the case of repair and maintenance work that results in a change to the internal or external configuration of a building, a request for as-built drawings shall be deemed as having been made by the U.S. Forces. These as-built drawings will be provided in digitized format only if specifically requested by the U.S. Forces and coordinated with the German authorities.</p> <p>7.7.2 The extent of the turnover documentation shall be in accordance with the RBBau Part H (e.g. operation and maintenance manuals, repair parts lists, etc) and shall be provided to the U.S. Forces in the German and English languages. In deviation of Article 7.1.9 of the PoS / [UP], ABG 1975 the turnover documentation shall be provided at least 12 Workdays (Werktage) prior to scheduled turnover, if specifically requested by the U.S. Forces. This also applies to any specified “hands-on” training/technical instruction. Additional documentation that is requested by the U.S. Forces and not covered in the RBBau (Part H) shall be processed IAW Articles <a href="#">10.2.2</a> and <a href="#">10.2.3</a> of these Implementing Instructions. If essential documents and instruction are not provided on time and the start of operation is thus prevented, the U.S. Forces may refuse the acceptance/turnover of the facility. This applies also in the event of a phased turnover.</p> <p>7.8 Details to Article 7.2 ABG 1975 shall be determined prior to the execution. Thereby, the contracting parties will be represented on the</p>	

III. <u>ABG 1975 (U.S.)</u>	<u>Protocol of Signature (PoS / UP), Cover Letter (CL / BglB) and Implementing Instructions (IIs / RiABG)</u>	<u>Notes</u>
<p>The handling of contracts shall include processing any changes requested or approved in writing by Forces while work is in progress.</p> <p>7.1.8 Acceptance of the construction works or services performed by contractors according to the provisions of the Verdingungsordnung für Bauleistungen (Contracting Regulations for Construction Works), Verdingungsordnung für Leistungen (Contracting Regulations for Services), and turnover of the completed facilities to the Forces according to the procedure provided for in the “Richtlinien für die Durchführung von Bauaufgaben des Bundes im Zuständigkeitsbereich der Finanzbauverwaltungen” (RBBau), Part H, Bauübergabe, and <a href="#">Article 14</a> of this agreement. The documents mentioned in that part of the RBBau shall be transmitted to the Forces.</p> <p>7.1.8.1 On the delivery by the German authorities of parts of construction works which are capable of being put into use:</p> <p>provision at the same time of relevant manuals and operating instructions and the necessary briefing of personnel.</p> <p>7.1.8.2 Providing the Forces with a list of guarantee periods.</p> <p>7.1.8.3 Three months before the end of a period of guarantee the German authorities, upon the invitation of the Forces, will</p>	<p>German side by the Bauamt, on the U.S. Forces side by the agency requesting the repair of maintenance measures from the German authority.</p> <p>7.9 The prime purpose of the waiver which the U.S. Forces may grant under Articles 7.2 and 7.3 ABG 1975 for certain documents or certain tasks is to ensure that the construction project is carried out without avoidable delays and in the most economical manner possible. The German authorities will be informed of the waiver in good time.</p> <p>7.10 Details to Article 7.5 ABG 1975 are settled by the forms (encl. 1) [Appendix I of this handbook] and flow charts (encl. 2) [Appendix II of this handbook] attached to these implementing instructions. The agency responsible for technical supervision which always has to be involved will inform the responsible Federal Institute for Real Estate (Bundesanstalt für Immobilienaufgaben) on the project of the U.S. Forces with copy of Form ABG 3.</p> <p>7.11 When the KVM-Bau, HU-Bau, and AFU-Bau documents are transmitted by the Bauamt to the agency responsible for technical supervision, copies of these documents shall simultaneously be forwarded to the U.S. Forces for review.</p> <p>7.12 The principle of the unit price contract in accordance with VOB/A Article 5 No. 1a shall be adhered to, except in the cases where the U.S. Forces are compelled by their budgetary laws to conclude the lump sum contract and the prerequisites of VOB/A Article 5 No. 1b are fulfilled. The U.S. Forces will inform thereof, with their request for services provided for in Article 7.1.4 ABG 1975, on Form ABG 3.</p> <p>7.13 The invitation of the U.S. Forces to the German authorities to conduct a guarantee inspection, as mentioned in Art 7.1.8.3 ABG 1975, shall be deemed as having been made for all projects costing more than 150,000 Euro. In such cases the German authorities shall agree on a date of the inspection with the U.S. Forces at least 1 month in advance.</p>	

III. <u>ABG 1975 (U.S.)</u>	Protocol of Signature (PoS / UP), Cover Letter (CL / BglB) and <u>Implementing Instructions (IIs / RiABG)</u>	<u>Notes</u>
<p>inspect with the latter the completed construction works or parts thereof.</p> <p>7.1.9 In the case of new construction, alterations and extensions and upon request in the case of repair and maintenance:</p> <p>providing the Forces with reproducible as-built drawings showing the construction work carried out, parts lists, and other publications applicable to the completed construction works.</p> <p>7.1.9.1 At the request of the Forces:</p> <p>preparation of forecasts of the payments which will foreseeably have to be charged against the account of the Forces during the financial year concerned.</p> <p>7.1.9.2 Observation of the regulations for protective trade rights, patent rights and copyrights applicable in the Federal Republic of Germany.</p> <p>7.1.9.3 Timely enforcement of all claims, warranties and performance or penalty clauses for the benefit of the Forces.</p> <p>7.2 In the case of repair and maintenance work certain of the tasks set out in this Article can be dispensed with the agreement of both parties.</p> <p>7.3 The Forces may waive in writing the submission of certain documents or the execution of certain tasks by the German</p>		

III. <u>ABG 1975 (U.S.)</u>	Protocol of Signature (PoS / UP), Cover Letter (CL / BglB) and <u>Implementing Instructions (IIs / RiABG)</u>	<u>Notes</u>
<p>authorities. This shall be without prejudice to the provisions concerning compensation contained in <a href="#">PART II, Section D</a>.</p> <p>7.4 Construction works or contracts, including term contracts, shall not be amended, suspended or prematurely terminated by the German authorities without prior written agreement of the Forces.</p> <p>7.5 The form, number of copies and distribution of documentation for the above tasks shall be as specified in implementing instructions to this Agreement.</p>		
<p><b>◀◀ <u>Article 8 [Special Types of Contracts]</u></b></p> <p>8.1 The Forces may request the German authorities to carry out:</p> <p>8.1.1. repair and maintenance and minor new construction, alterations and extension by means of term contracts, multi-trade contracts or any other appropriate form of contracting;</p> <p>8.1.2. major new construction, alterations and extensions by means of multi-trade contracts or any other appropriate form of contract.</p> <p>8.2 The requests of the Forces shall be met as far as they are in accordance with German legal provisions.</p>	<p style="text-align: center;"><b>IIs - Re Article 8</b></p> <p>8.1 If the U.S. Forces have special requests in regard to the types of contracts mentioned in Article 8.1.1 and 8.1.2 ABG 1975, they shall inform the responsible Bauamt thereof in good time, however no later than at the time they place the order for performance of the services provided for in <a href="#">Article 7.1.4</a> ABG 1975 with Form ABG 3.</p> <p>8.2 The request of the U.S. Forces for services by means of term contracts can - unless agreed upon otherwise - be submitted on Form ABG 6 in accordance with the flow chart (encl. 2) [Appendix II of this handbook].</p> <p>8.3 Orders for construction work under term contract may only be placed if the order amount for the work described in specifications does not exceed the limit for a construction project within the meaning of <a href="#">Article 1.8</a> ABG 1975 which was established in the Vergabe- und Vertragshandbuch (manual for awarding Federal contracts; Guideline to Standard Form Nr. 617).</p> <p>8.4 The Bauämter will coordinate with the U.S. Forces for which accommodation areas and for which trades term contracts shall be</p>	

III. <u>ABG 1975 (U.S.)</u>	<b>Protocol of Signature (PoS / UP), Cover Letter (CL / BglB) and Implementing Instructions (IIs / RiABG)</b>	<u>Notes</u>
	<p>concluded. It is thereby possible - if this appears appropriate - to conclude one joint term contract for accommodations used by the German agencies and accommodations used by the U.S. Forces.</p> <p>8.5 If the Bauamt concluded a term contract for accommodations used by the U.S. Forces and it was agreed that the Bauamt shall place the individual orders, the U.S. Forces may directly request necessary services, outside the office hours of the Bauamt, in cases of emergency or for other special reasons. In such an event, the Bauamt will issue the individual order for these services later on in writing.</p> <p>8.6 In individual cases requiring adherence to schedules or costs resulting from U.S. budgetary constraints of the U.S. Forces or for military reasons, the U.S. Forces may request (in accordance with Articles 8.1.1 and 8.1.2. ABG 1975) to execute construction works on the basis of contracts including several or even all trades. The requests shall be submitted and justified on Form ABG 3 to the responsible German construction office in a timely manner, however no later than at the time the services are ordered in accordance with <a href="#">Article 7.1.4</a> ABG 1975. In individual cases it is the responsibility of the German authorities to advise the U.S. Forces concerning the drafting of contracts awarded using the indirect procedure to assure observance to the legal and administrative regulations in force.</p>	
<p><b>◀◀ <u>Article 9 [Adherence to the Principle of Economical Efficiency, Timelines and Safety and Security Requirements]</u></b></p> <p>The German authorities shall ensure that construction works are carried out according to the plans and specifications, as economically as possible, and within the mutually agreed time, and that all safety and security requirements are met.</p>	<p style="text-align: center;"><b>PoS - re Article 9</b></p> <ol style="list-style-type: none"> <li>1. The U.S. Forces may prescribe any special security measures including but not limited to access to the site of the work, issuance of passes, and clearances of contractors or their employees.</li> <li>2. The agreed rules and limitations shall be included in the invitation for tenderers.</li> </ol> <p style="text-align: center;"><b>IIs - Re Article 9</b></p> <p>9.1 If there is indication that the agreed upon schedules cannot be met for any phase of the project, the U.S. Forces and the German authorities will notify each other in a timely manner of any pending delay and reasons for the delay and will propose alternative courses of action for</p>	

III. <u>ABG 1975 (U.S.)</u>	<b>Protocol of Signature (PoS / UP), Cover Letter (CL / BglB) and Implementing Instructions (IIs / RiABG)</b>	<u>Notes</u>
	<p>consideration and remedying. The same applies for cost growth exceeding the approved amount of funds and/or scope of work.</p> <p>9.2 Any change to an agreed construction completion date must be approved by the forces using the Form ABG 5. For each new ABG 5 Form submitted the Bauamt will consult with the U.S. authorities to determine if and when the construction time schedule needs to be updated.</p>	
<p> <b><u>Article 10 [Letter(s) of Request on Execution Requirements]</u></b></p> <p>10.1 The Forces shall transmit to the German authorities:</p> <p>10.1.1. Letter(s) of request for the execution of one or more of the tasks described in <a href="#">Article 7</a> of this Agreement;</p> <p>10.1.2. their approval of the "Kostenvoranmeldung-Bau";</p> <p>10.1.3. their approval of the "Haushaltsunterlage-Bau";</p> <p>10.1.4. their approval of the "Ausführungsunterlage-Bau"; and</p> <p>10.1.5. their concurrence in the award of contract(s).</p> <p>10.2 The Forces may have construction works altered, suspended or terminated at any stage by notifying the German authorities in writing.</p> <p>10.3 The form, number of copies, and distribution of documentation for the above tasks shall be specified in</p>	<p style="text-align: center;"><b>PoS - re Article 10</b></p> <p>1. The German authorities will signify their acceptance of U.S. Forces' requests by promptly signing and dating ABG Form 3, and promptly returning a signed copy thereof to the U.S. Forces.</p> <p>2. The rights and liabilities in relation to the contractor arising from the termination at the request of the U.S. Forces of a contract awarded by the German authorities must be determined in accordance with the German legal provisions applying to public construction.</p> <p style="text-align: center;"><b>IIs - Re Article 10</b></p> <p>10.1 Form ABG 3 serves as letter of request under Article 10.1.1 ABG 1975. The flow of the request is represented schematically in enclosure 2 [Appendix II of this handbook] to these Implementing Instructions.</p> <p>10.2.1 Approvals under Articles 10.1.2 - 10.1.4 ABG 1975 are also granted on Form ABG 3. Any restrictions or requests for changes will be indicated under "remarks".</p> <p>10.2.2 During preparation of the Form ABG 3 and as soon as detailed requirements are available the U.S. forces will coordinate the type, scope, approximate time schedule, and estimated cost for each project-specific additional service in support of the design (e.g. land survey, topographic survey, soil survey, hazardous material survey, or building structural survey, environmental compatibility survey, energy consumption analysis) and/or construction phases (e.g. landfill fees, ordnance clearance/removal, management of</p>	

III. <u>ABG 1975 (U.S.)</u>	<b>Protocol of Signature (PoS / UP), Cover Letter (CL / BglB) and Implementing Instructions (IIs / RiABG)</b>	<u>Notes</u>
<p>implementing instructions to this Agreement.</p>	<p>contaminated materials, and compensatory and replacement measures that do not fall under <a href="#">Article 21.2</a> of these Implementing Instructions) with the German authorities.</p> <p>10.2.3 If additional services to those referred to in Article 10.2.2 of these Implementing Instructions (those which are not covered by ABG-3) in support of the design and/or construction phases or additional funds for a previously ABG 3 approved service are needed, they are to be requested by the German authorities using Form ABG 5 or by the U.S. Forces using Form ABG 5A prior to the letting or amending of contracts for any such services by the German authorities.</p> <p>10.2.4 As soon as the Bauamt becomes aware during the preparation of the concept design (HU-Bau) or the final design (AFU-Bau) that the estimated construction cost approved according to Articles 10.1.2 or 10.1.3 ABG 1975 will be exceeded, the German authority will notify the U.S. authorities immediately in writing. The U.S. authorities will promptly notify the German authority in writing how to proceed with the design work (e.g. stop work, change scope or continue design with original scope).</p> <p>10.3 The agreement under Article 10.1.5 ABG 1975 will be granted by return of Form ABG 4 with completed Part II.</p> <p>10.4 As soon as the amounts acknowledged by the U.S. Forces on Forms ABG 4 and 5 exceed the amount indicated on Form ABG 3, the U.S. Forces shall enter an increase in the amount by an appropriate note on Forms ABG 4/5. If the amount on Form ABG 3 is not reached with the last Forms ABG 4/5 which is to be acknowledged by the U.S. Forces within the framework of this construction project, the U.S. Forces will decrease this amount accordingly.</p>	
<p>◀◀ <b><u>Article 11 [Description of Construction Works]</u></b></p> <p>The letter of request shall be accompanied by an adequate description of construction works required.</p>	<p><b>IIs - Re Article 11</b></p> <p>The "adequate description" shall include at least the following:</p> <p>11.1 A general description of the requested construction project as a whole.</p>	

III. <u>ABG 1975 (U.S.)</u>	<b>Protocol of Signature (PoS / UP), Cover Letter (CL / BglB) and Implementing Instructions (IIs / RiABG)</b>	<u>Notes</u>
	<p>11.2 Information on type, size, use, purpose, location, and development measures and subsequent facilities required in this connection (with plans as appropriate, but at least a site plan).</p> <p>11.3 Requested work commencement and completion dates.</p>	
<p><b>◀◀ <u>Article 12 [Funding Procedures]</u></b></p> <p>12.1 Together with the letter of request (<a href="#">Article 10.1.1</a>), the Forces shall inform the German authorities of the funds budgeted for the individual construction works.</p> <p>12.2 The amount of funds available for the execution of individual construction works shall be notified to the German authorities together with the approval of the “Haushaltsunterlage-Bau” (<a href="#">Article 10.1.3</a>).</p> <p>12.3 The contract amounts (<a href="#">Article 7.1.6</a>) may not be committed or exceeded unless written approval of the Forces has been obtained.</p> <p>12.4 If, in the case of any particular construction works, any additional funds are expected to be required, the German authorities shall inform the Forces of the probable amount of this requirement, and, as soon as possible thereafter, transmit a full statement of the reasons for, and a detailed schedule of, the additional requirement of funds.</p> <p>12.5 Any costs in excess of the amount approved by the Forces (Article 12.3) will not be borne by them unless their</p>	<p style="text-align: center;"><b>PoS - re Article 12.4</b></p> <p>Requirements for additional funds must be furnished in writing to be received by the U.S. Forces not less than one month before such funds are required.</p> <p style="text-align: center;"><b>CL - re Article 12</b></p> <p>Costs in excess of funds budgeted for contract execution in accordance with Article 12 shall not be incurred without the prior consent of the U.S. Forces. This does not apply to expenditures as provided for in <a href="#">Article 16.1.2.5</a>.</p> <p style="text-align: center;"><b>IIs - Re Article 12</b></p> <p>12.1 "Budgeted funds" within the meaning of Article 12.1 ABG 1975 are funds earmarked by the U.S. Forces, on the basis of their own estimates, in their budget.</p> <p>12.2 The "amount available" within the meaning of Article 12.2 ABG 1975 establishes the financial limits for the services to be rendered. The provisions of <a href="#">Article 10.2.4</a> of these Implementing Instructions shall be observed.</p> <p>12.3 The "contract amounts" within the meaning of Article 12.3 ABG 1975 and the "amounts approved" within the meaning of Article 12.5 ABG 1975 are those amounts which the U.S. Forces confirmed as established on part II of Forms ABG 4/5. As soon as the Bauamt becomes aware that the approved contract amount will be exceeded, the Bauamt will immediately notify the U.S. authorities in writing and provide the reasons for the cost increases. The U.S. authorities will promptly ascertain in writing which already awarded work items will be put on hold until a decision is reached on the availability of additional funding or will be not be executed to</p>	



III. <u>ABG 1975 (U.S.)</u>	<b>Protocol of Signature (PoS / UP), Cover Letter (CL / BglB) and Implementing Instructions (IIs / RiABG)</b>	<u>Notes</u>
prior approval for these additional funds has been obtained.	<p>reduce costs. The Bauamt will not permit work to be executed that exceeds the approved contract amount and is not approved in writing by U.S. authorities, even if thereby construction delays were to occur. All German and U.S. agencies involved in the change order approval process are committed to take all feasible steps to preclude construction delays.</p> <p>12.4 To Article 12.5 ABG 1975, see also the exception provided for in Article <a href="#">16.1.2.5</a> ABG 1975.</p>	
<p><b>◀◀ Article 13 [Inspections, Determination of Deficiencies]</b></p> <p>13.1 Persons designated by the Forces may at any time have access to construction works and, after prior arrangement with the German authorities, participate in joint inspections of constructions works, scrutinize plans and all relevant documents and accounts and, either before or after the final accounts are made up, examine locally the documents supporting the payments or requests for payments made by the competent German offices.</p> <p>13.2 If the Forces discover defects or deficiencies, these shall be reported to the German authorities immediately.</p> <p>13.3 All defects and deficiencies discovered while work is in progress and all measures (relating to scope, time limits and similar matters) envisaged for remedying these defects or deficiencies shall be entered in a joint record.</p>	<p><b>IIs - Re Article 13</b></p> <p>13.1 For the preparation of final acceptance (See also VOB-Part B) and/or turnover of construction work to the U.S. Forces, the Bauamt may arrange for an inspection of the work together with the U.S. Forces prior to completion.</p> <p>13.2 In cases of this nature, the Bauamt will take action so that the contractors immediately correct the jointly noted omissions and deficiencies.</p> <p>13.3 The joint record mentioned in Article 13.3 ABG 1975 will be kept on files at the Bauamt. The U.S. Forces will be furnished a copy thereof.</p>	
<p><b>◀◀ Article 14 [Turnover; Final Inspection]</b></p>	<p><b>IIs - Re Article 14</b></p>	

III. <u>ABG 1975 (U.S.)</u>	<u>Protocol of Signature (PoS / UP), Cover Letter (CL / BglB) and Implementing Instructions (IIs / RiABG)</u>	<u>Notes</u>
<p>14.1 Completed structures or, as the case may be, completed sections of construction works, shall be accepted by the Forces without delay, but not later than 12 working days after the German authorities have offered to hand them over.</p> <p>The German authorities shall hand over the sections suitable for use mentioned above within the above-mentioned period as soon as the Forces have requested the handing over.</p> <p>The time-limit of 12 working days may only be exceeded for cogent reasons. Where it appears that this time-limit may be exceeded, the Forces will notify the German authorities promptly and present their reasons.</p> <p>14.2 The Forces may refuse in writing to take over construction works which have by virtue of defects or deficiencies are rendered unacceptable or not suitable for use.</p> <p>14.3 All defects and deficiencies established during a final inspection of finished construction works together with the measures (relating to scope, time-limits, etc.) proposed for remedying them shall be laid down in joint minutes and the German authorities shall ensure that the appropriate measures are implemented.</p> <p>All defects and deficiencies arising after the take-over of the structure shall be</p>	<p>14.1 The offer by the Bauamt to hand over a completed section of construction works to the U.S. Forces shall be made in writing. Each one copy shall be forwarded to the agency responsible for technical supervision and the responsible Federal Institute for Real Estate (Bundesanstalt für Immobilienaufgaben) under Article 48 SA NATO SOFA.</p> <p>14.2 Form ABG 7 shall be used for the joint minutes mentioned in Article 14.3 ABG 1975. The enclosures listed under item 6 of the form shall be handed over to the U.S. Forces. (As regards the as-built drawings and the documents required for putting technical facilities into service as well as “practical and technical instructions”, see also <a href="#">Article 7.7</a> of these Implementing Instructions).</p> <p>14.3 The Bauamt will inform the U.S. Forces in writing of the correction of the noted omissions and deficiencies.</p>	

III. <u>ABG 1975 (U.S.)</u>	Protocol of Signature (PoS / UP), Cover Letter (CL / BglB) and <u>Implementing Instructions (IIs / RiABG)</u>	<u>Notes</u>
reported to the German authorities in good time prior to the expiration of the warranty periods and the German authorities will provide immediately for their rectification under the warranty.		
 <b><u>Article 15 [Procedure and Costs in Case of Disputes]</u></b>  As regard procedures and costs in connection with litigation arising from contracts made by the German authorities on behalf of the Forces, Article 44 of the SA NATO SOFA and the administrative agreements made there under shall apply.	<b>IIs - Re Article 15</b>  The administrative agreements concluded to Article 44 SA NATO SOFA between the Federal Ministry of Finance and the U.S., Belgian, British, French, and Canadian Forces are published in Supplement 5/75 to the Federal Gazette No. 25 of 6 February 1975 and supplemented on 12 November 1980 (Federal Gazette No. 223 of 29 November 1980).	

III. <u>ABG 1975 (U.S.)</u>	Protocol of Signature (PoS / UP), Cover Letter (CL / BglB) and <u>Implementing Instructions (IIs / RiABG)</u>	<u>Notes</u>
-----------------------------	------------------------------------------------------------------------------------------------------------------	--------------

**SECTION C - COSTS TO BE BORNE BY THE U.S. FORCES**

 <u>Article 16 [Costs to be Borne by the Forces]</u>	PoS - re Article 16.1.3	
16.1 The following costs shall be borne by the Forces:	<p>The costs for other services performed by the construction contractor and not expressly excluded by the provisions of ABG 1975 which, in the opinion of the U.S. Contracting Officer, should be included in the cost of the construction work are deemed to be "other payments made with the approval of the U.S. Forces." Where such costs are allowed by the U.S. Contracting Officer, they shall be specifically certified as being allowable under this Article.</p> <p style="text-align: center;"><b>IIs - Re Article 16</b></p>	
16.1.1 the cost of the contractual services of the contractors;		
16.1.2 all other unavoidable costs in the following cases:	<p>16.1 Re Articles 16.1 and 16.1.2 ABG 1975, see also Articles <a href="#">12.3</a> and <a href="#">12.5</a> ABG 1975.</p> <p>16.2 Insofar as guarding provided for in Article 16.1.2.1 ABG 1975 is required, the Bauamt shall inform the responsible agency of the U.S. Forces in order to give the U.S. Forces the opportunity to provide their own guarding. In the event of a guarding of the construction work by the U.S. Forces, the Forces will also assume responsibility linked therewith.</p> <p>16.3 Before the measures provided for in Article 16.1.2.5 ABG 1975 are initiated, the approval of the U.S. Forces shall be obtained. The U.S. Forces shall furnish written confirmation of their approval. The emergencies within the meaning of Article 16.1.2.5 ABG 1975 include e.g. storms, floods, riots; and earthquakes.</p> <p>16.4 Subject to the provision that no costs may be incurred unless the scope of the services and estimated cost are approved by the U.S. Forces before any contracts are let for these services by the German authorities, the U.S. Forces approve the following payments for the purposes of Article 16.1.3 ABG 1975:</p> <p>16.4.1 Costs for public legal procedures (i.e. fees for special permits, licenses or other official permissions).</p>	
16.1.2.1 the cost of any necessary guarding of a construction work during the period from take-over by the German authorities from the contractor to the handover to the Forces.		
16.1.2.2 the cost of surveying a property, of any topographic surveying and of major soil tests which are required for the execution of construction works and which cannot be furnished by the German construction authorities provided that these are previously agreed to by the Forces.		
16.1.2.3 the cost of the provision of a model, of orders placed with artists, of general cleaning (grounds, windows, etc.) and of winter work in so far as the Forces have requested these in writing.		
16.1.2.4 the cost of the celebration of completion of the main structure (Richtfest) within the limits accepted in the "Haushaltsunterlage-Bau" and of other		

III. <u>ABG 1975 (U.S.)</u>	<u>Protocol of Signature (PoS / UP), Cover Letter (CL / BglB) and Implementing Instructions (IIs / RiABG)</u>	<u>Notes</u>
<p>ceremonies if these have been agreed previously.</p> <p>16.1.2.5 expenditures arising out of measures taken by the German authorities in emergencies in order to safeguard the interests of the Forces;</p> <p>16.1.3 other payments made with the approval of the Forces.</p> <p>16.2 These provisions shall be without prejudice to the provisions relating to costs contained in the SA NATO SOFA, in particular the provisions of <a href="#">Articles 49</a> and 63.</p>	<p>16.4.2 If required in connection with a construction project, costs for surveys of sites contaminated by the U.S. Forces, by means of studies to be requested (e.g. to determine alternative remediation or disposal methods) and any fee charged in respect of proper disposal of such contaminated material.</p> <p>16.4.3 Costs for updating as-built drawings in cases where the U.S. Forces made facility modifications, carried out under the direct procedure - in cases of repair work to the extent necessary - or in cases where the designation of the responsible agency that made facility modifications is unclear, as far as such services are requested by the U.S. Forces.</p> <p>16.4.4 Costs for converting common German CADD formats to other specific formats, as well as costs for digitization of existing prints or hand drafted drawings needed to prepare drawings in a common German commercial CADD format.</p> <p>16.4.5 All associated costs in accordance with Article 16.4 of these Implementing Instructions will be included in the ABG 3 document.</p> <p>16.4.6 If not included in the ABG 3 document but later determined to be necessary, the above listed services referred to in 16.4.1 to 16.4.4 of these Implementing Instructions shall be requested and approved prior to start of any work, through a modification of the Form ABG 3 or by using Form ABG 5 or ABG 5A.</p> <p>16.5 The U.S. Forces agree to pay the costs of obtaining from third parties the health and safety coordinator services required under the Health and Safety Regulations at Construction Sites (Baustellenverordnung - Baustell IV). However, the express approval of the U.S. Forces must be obtained before incurring costs in relation to these services in the following circumstances:</p> <p>in relation to services during the design phase of a construction project, where the proposed costs exceed 0.4% of the total building costs, and</p>	

III. <u>ABG 1975 (U.S.)</u>	<u>Protocol of Signature (PoS / UP), Cover Letter (CL / BglB) and Implementing Instructions (IIs / RiABG)</u>	<u>Notes</u>
	<p>in relation to services during the construction phase, where the proposed costs exceed 0.6% of the total building costs.</p> <p><a href="#">Article 5.3</a> ABG 1975 shall be taken into account.</p> <p>The German authorities shall ensure that any contract for the provision of health and safety coordinator services during the design or construction execution phases, or any contract including those services, shall only be awarded following competition, and, wherever possible, only be provided by the construction contractor during the construction execution phase.</p>	
<p><b>◀◀ <u>Article 17 [Special Cases of Costs to be Borne by the Forces]</u></b></p> <p>The Forces shall bear the costs resulting from the removal of damages or deficiencies for which the contractors are not liable, including the costs in those cases where damage is the result of force majeure, war or other inevitable circumstances.</p> <p>The approval of the Forces shall be obtained before repairs are undertaken.</p>	<p><b>CL - re Article 17</b></p> <p>The term "other inevitable circumstances" may, in certain cases, include the term "riot".</p> <p><b>IIs - Re Article 17</b></p> <p>The U.S. Forces shall confirm their approval in writing.</p>	
<p><b>◀◀ <u>Article 18 [Cases of Costs not to be Borne by the Forces]</u></b></p> <p>The costs mentioned in Article <a href="#">15</a>, <a href="#">16</a>, and <a href="#">17</a> of this Agreement, as well as any other costs, shall not be borne by the Forces if they are paid by a third party or if they are proved to be the fault of officials or employees of the German authorities or other persons engaged by them.</p>	<p><b>IIs - Re Article 18</b></p> <p>See hereto Article <a href="#">25.1</a> ABG 1975.</p>	
<p><b>◀◀ <u>Article 19 [Construction Site Offices; Construction Site Supervision]</u></b></p> <p>19.1 If there is office accommodation of the Forces available on any building site or in its vicinity, which is not used by them, they shall make it available,</p>	<p><b>PoS - re Article 19</b></p> <p>Where office accommodation is unavailable, no costs shall be incurred by the U.S. Forces. Such costs incurred by the German authorities are included in the compensation for administrative costs.</p> <p><b>IIs - Re Article 19</b></p>	

III. <u>ABG 1975 (U.S.)</u>	Protocol of Signature (PoS / UP), Cover Letter (CL / BglB) and <u>Implementing Instructions (IIs / RiABG)</u>	<u>Notes</u>
<p>including toilets and washrooms as well as water and central heating installations, free of charge to the German authorities for use by their staff. The German authorities shall, however, provide the furniture and pay for the heating, lighting, cleaning and telephone charges.</p> <p>19.2 On other building sites the Forces shall make office accommodation available to the German authorities free of charge as soon as this can be set up in the buildings on the site already completed and handed over. This shall be effected on the condition laid down in Article <a href="#">19.1</a>.</p> <p>19.3 If continuous guarding of a building site is necessary or expedient, the German authorities and the Forces may agree on special arrangements deviating from these specified above.</p>	<p>The Bauamt shall confirm the take-over and the condition of the office accommodation provided by the U.S. Forces under Article 19 ABG 1975. On return of the office accommodations to the U.S. Forces, they must be restored to their original condition.</p>	

III.	<u>ABG 1975 (U.S.)</u>	<b>Protocol of Signature (PoS / UP), Cover Letter (CL / BglB) and Implementing Instructions (IIs / RiABG)</b>	<u>Notes</u>
------	------------------------	-------------------------------------------------------------------------------------------------------------------	--------------

<b>SECTION D - COMPENSATION OF THE GERMAN AUTHORITIES</b>			
	<b><u>Article 20 [Scope of Compensation]</u></b>	<b>PoS - re Article 20</b>	
20.1	In the case of completed construction works, the German authorities shall receive compensation, determined and calculated pursuant to Articles 21 up to 24 below, for their services as full remuneration for all costs directly or indirectly incurred by them, irrespective of whether these services are rendered by the staff of the German authorities or by third parties.	<ol style="list-style-type: none"> <li>1. A belated transmission within the meaning of Article 20.2 is deemed to be any further request made to the German authorities by U.S. Forces after preparation and submission of the documents provided for in <a href="#">Article 7.1.3</a>.</li> <li>2. "Adequate compensation for any additional planning work" under Article 20.2 shall, in general, be determined in accordance with the percentages shown in <a href="#">Article 23</a>.</li> </ol>	
		<b>IIs - Re Article 20</b>	
20.2	The German authorities shall also be paid adequate compensation for any additional planning work if this has become necessary as a result of the belated transmission to them of the request for the observance of Forces' regulations or standards (under Articles <a href="#">4.2</a> and <a href="#">4.3</a> ).	20.1 For additional planning work other than the work mentioned in Article 20.2 ABG 1975 resulting from design changes requested by the U.S. Forces, the German authorities will receive compensation to be calculated in accordance with <a href="#">Article 24</a> ABG 1975, only if such changes are requested after the KVM-Bau has been approved.	
20.3	The German authorities will provide the following services without compensation:	20.2 Additionally, services that are required as a result of U.S. Forces' requests for design changes made prior to approval of the KVM Bau are to be adequately reimbursed if substantial planning works or substantial parts of the planning work have to be repeated. The U.S. Forces are not required to pay additional compensation for planning services that were carried out without the prior consent of the U.S. Forces.	
20.3.1	One repetition of the invitation to tender, using the same, amended or slightly altered tender documents. If the result of the first invitation to tender was not acceptable to the Forces for budgetary reasons;	20.3 When the U.S. Forces request solicitation of construction services by way of deductive items (Reference <a href="#">Article 5.9</a> of these Implementing Instructions), the services will be separately compensated, even in cases when one or more deductive items are not awarded. In such cases, the increased construction costs that would have resulted if the work had been awarded will be used as the basis for the calculation of the compensation for the services provided. By agreement with the U.S. Forces further details may be promulgated by decree (Erläss).	
20.3.2	the rectifying of faulty plans and specification schedules; and		
20.3.3	administrative participation in the demolition and reconstruction of		



III. <u>ABG 1975 (U.S.)</u>	Protocol of Signature (PoS / UP), Cover Letter (CL / BglB) and <u>Implementing Instructions (IIs / RiABG)</u>	<u>Notes</u>
<p>structures which are faulty or do not correspond to the approved plans and specification schedules, or which were built on the basis of faulty plans or specification schedules.</p> <p>20.4 The provisions shall be without prejudice to the provisions concerning costs in Articles <a href="#">16</a>, <a href="#">17</a> and <a href="#">18</a> above.</p>		
<p><b>◀◀ <u>Article 21 [Basis of Compensation]</u></b></p> <p>21.1 The compensation for any specific construction works shall be calculated as a percentage of the building costs pursuant to Article 21.3.</p> <p>21.2 The total of all services to be rendered on any one building site within the framework of one “Haushaltsunterlage-Bau”, shall be deemed to be one construction work within the meaning of Article 21.1.</p> <p>21.3 The following actual expenditures (with the exception of those taxes and customs duties from which the Forces are exempt) shall be treated as building costs for the purposes of computing compensation:</p> <p>21.3.1 the cost of the site preparation, but only in so far as such work has been planned by the German building authorities;</p> <p>21.3.2 the cost of site development, but only in so far as such work has been planned by the German building authorities;</p> <p>21.3.3 the cost of construction works;</p>	<p style="text-align: center;"><b>IIs - Re Article 21</b></p> <p>The construction costs allowable according to Article 21.1 ABG 1975, also include:</p> <p>21.1 the cost for transporting material of any kind from the construction site to the disposal site. Any fee charged in respect of disposal of such material at the disposal site shall not be included.</p> <p>21.2 the cost for compensatory and replacement measures, provided that such measures are performed on accommodations made for exclusive use of the U.S. Forces (Ref <a href="#">Art 53, NATO SOFA SA</a>), are required as part of a construction project and are planned and executed by the German authorities IAW <a href="#">Art 7</a> ABG 1975.</p>	

III. <u>ABG 1975 (U.S.)</u>	<b>Protocol of Signature (PoS / UP), Cover Letter (CL / BglB) and Implementing Instructions (IIs / RiABG)</b>	<u>Notes</u>
<p>21.3.4 the cost of equipment, unless provided by the Forces;</p> <p>21.3.5 the cost of external installations which is borne by the Forces, but only in so far as such work has been planned by the German building authorities;</p> <p>21.3.6 the cost of additional measures, but only in so far as expressly requested by the Forces;</p> <p>21.3.7 the costs incidental to construction, but only the cost of supplying a model and orders placed with artists in so far as explicitly requested by the Forces, and the cost of the celebration of completion of the main structure (Richtfest) within the limits accepted in the “Haushaltsunterlage-Bau”.</p>		
<p> <b><u>Article 22 [Factors of Computing Compensation]</u></b></p> <p>22.1 The following cost shall not be treated as building costs for the purpose of computing compensation pursuant to <a href="#">Article 21.3</a>:</p> <p>22.1.1 real estate purchase and incidental costs (DIN 276);</p> <p>22.1.2 the incidental building costs (DIN 276) with the exception of the costs set out in <a href="#">Article 21.3.7</a>;</p> <p>22.1.3 the cost of celebrations and ceremonies (with the exception of the “Richtfest”</p>	<p style="text-align: center;"><b>IIs - Re Article 22</b></p> <p>No comments.</p>	

III. <u>ABG 1975 (U.S.)</u>	Protocol of Signature (PoS / UP), Cover Letter (CL / BglB) and <u>Implementing Instructions (IIs / RiABG)</u>	<u>Notes</u>
<p>within the limits accepted by the “Haushaltsunterlage-Bau”);</p> <p>22.1.4 the cost of surveying the boundaries of buildings sites, other land survey work and soil tests;</p> <p>22.1.5 the cost of the services of consultants engaged by the German authorities; and</p> <p>22.1.6 the cost of proceedings in and out of court and any interest payable under court judgments or in respect of settlements made in or out of court.</p>		
<p>◀◀ <b>Article 23 [Rates of Compensation]</b></p> <p>23.1 The percentages within the meaning of <a href="#">Article 21</a> for construction works shall be as follows:</p> <p>23.1.1 seven percent (7%) for:</p> <p>for repair and maintenance, very minor construction, alterations and extensions, minor new construction, alterations and extensions; as well as term contracts not covered by Article 23.1.2;</p> <p>23.1.2 five percent (5%) for:</p> <p>major new construction, alterations and extensions, as well term contracts where the Forces perform a significant proportion of the administrative duties.</p>	<p style="text-align: center;"><b>PoS - re Article 23</b></p> <p>(1) In the execution of construction works under the indirect procedure in accordance with <a href="#">Part II, ABG 1975</a>, the German authorities will provide the following documents both in German and in an English translation:</p> <ol style="list-style-type: none"> <li>1. “Kostenvoranmeldung-Bau” (<a href="#">Article 7.1.2</a>, ABG 1975) <ol style="list-style-type: none"> <li>a. Informal explanatory report</li> <li>b. General location plans</li> <li>c. Building expert's technical report as to the suitability of the site</li> </ol> </li> <li>2. “Haushaltsunterlage-Bau” (<a href="#">Article 7.1.3</a>, ABG 1975) <ol style="list-style-type: none"> <li>a. Plans</li> <li>b. Explanatory Report</li> <li>c. Building expert’s technical report as to the suitability of the site (unless already included in the Kostenvoranmeldung-Bau)</li> </ol> </li> <li>3. “Ausführungsunterlage - Bau” (<a href="#">Article 7.1.4</a>, ABG 1975) <ol style="list-style-type: none"> <li>a. Design drawings</li> </ol> </li> </ol>	

III. <u>ABG 1975 (U.S.)</u>	Protocol of Signature (PoS / UP), Cover Letter (CL / BglB) and <u>Implementing Instructions (IIs / RiABG)</u>	<u>Notes</u>
	<p>b. Working drawings  c. Specifications  d. Revised versions of (a) through (c) where considered necessary after review by the U.S. Forces</p> <p>4. Construction Contract Modifications</p> <p>a. All modified plans and specifications  b. All documents to be enclosed with Change Order Document ABG 1975/ABG 5</p> <p>(2) In consideration of the translation costs arising to the German authorities, the percentages within the meaning of Article 23 shall be as follows:</p> <p>a. 7.5 percent for repair and maintenance, minor new construction alterations and extensions, as well as for term contracts not covered by Article 23.1.2.  b. 5.6 percent for major new construction, alterations and extensions, as well as for term contracts where the U.S. Forces perform a significant proportion of the administrative duties.</p> <p>(3) The rates set out in paragraph 2 above do not include the cost of translations relating to secondary [additional] services, e.g.</p> <ul style="list-style-type: none"> <li>- soil tests,</li> <li>- surveying,</li> <li>- energy budget analysis.</li> </ul> <p>The civil engineering firms concerned will prepare English translations in performing such services and will have the costs billed to the U.S. Forces on actual cost basis.</p> <p>(4) If the U.S. Forces determine that no translations as referred to in paragraph 1 are required for the performance of construction work, they will so inform the German authorities on their initial request (Form ABG 1975/ABG 3).</p>	

III. <u>ABG 1975 (U.S.)</u>	<u>Protocol of Signature (PoS / UP), Cover Letter (CL / BglB) and Implementing Instructions (IIs / RiABG)</u>	<u>Notes</u>
	<p>In such cases, the rates set out in Article 23, ABG 1975, i.e. 7 percent or 5 percent, shall be applied in calculating the compensation for administrative work.</p> <p>However, compensation will be calculated in accordance with the rates set out in paragraph 2 above if it is determined by the U.S. Forces that only part of the translations referred to in paragraph 1 is not required.</p> <p style="text-align: center;"><b>IIs - Re Article 23</b></p> <p>23.1 For minor repair and maintenance carried out in connection with major new construction, alterations and extensions and included together with these in one construction document, the compensation is governed by Article 23.1.2 ABG 1975 and the UP / [PoS] to Article 23.</p> <p>23.2 The rate of compensation of 5 percent or 5.6 percent, which was established in Article 23.1.2 ABG 1975 and UP / [PoS] re Article 23 for certain term contracts, shall apply if the U.S. Forces themselves participate in the handling of term contracts to such an extent that the German construction authority is relieved significantly, e.g. if the U.S. Forces themselves place the individual orders and perform settling of accounts.</p>	
<p>◀◀ <u>Article 24 [Compensation in case of Partial Services and Interruption; Costs of Consultants]</u></p> <p>24.1 Compensation, proportionate to the extent of the services rendered by the German authorities, shall also be payable, if construction works have been started but not completed at the request of the Forces, unless the German authorities have only performed services pursuant to <a href="#">Article 7.1.1</a> or have only provided simple technical opinions without employing the services of consultants.</p>	<p style="text-align: center;"><b>IIs - Re Article 24</b></p> <p>24.1 Articles 24.1 and 24.2 ABG 1975 are not only applicable for construction projects that are completely cancelled by the U.S. Forces, after construction has commenced, but also for those that are cancelled during the design stage. If the U.S. Forces request some or all of the services detailed in articles <a href="#">7.1.1 to 7.1.5</a> ABG 1975 with respect to construction works but these items are not included in the final awarded contract, the increased construction costs that would have resulted if the work had been awarded will be used as the basis for the calculation of the compensation for the services provided.</p> <p>24.2 When computing the compensation in application of the rates of compensation established in articles 24.1.1 thru 24.2 ABG 1975, the following example shall be taken as a basis:</p>	

III. <u>ABG 1975 (U.S.)</u>	<u>Protocol of Signature (PoS / UP), Cover Letter (CL / BglB) and Implementing Instructions (IIs / RiABG)</u>	<u>Notes</u>
<p>24.1.1 The German authorities shall receive for their services a part of the compensation which would have been payable pursuant to Articles 21 up to 23 if the construction works had been completed. The German authorities and the Forces shall jointly determine the total cost of the construction works which would have arisen had they been completed. The proportional compensation shall be determined as follows:</p> <p>24.1.1.1 five percent (5%) for services rendered pursuant to Article 7 up to and including <a href="#">Article 7.1.2</a>;</p> <p>24.1.1.2 twenty percent (20%) for services rendered pursuant to Article 7 up and including <a href="#">Article 7.1.3</a>;</p> <p>24.1.1.3 forty percent (40%) for services rendered pursuant to Article 7 up to and including <a href="#">Article 7.1.4</a>;</p> <p>24.1.1.4 fifty-five percent (55%) for service rendered pursuant to Article 7 up to and including <a href="#">Article 7.1.5</a>;</p> <p>24.1.1.5 sixty percent (60%) for services rendered pursuant to Article 7 up to and including <a href="#">Article 7.1.6</a>; and</p> <p>24.1.1.6 sixty-five percent (65%) for services rendered pursuant to Article 7 up to and including <a href="#">Article 7.1.7</a>, plus if applicable, an additional amount to be determined according to Article 24.1.2.</p>	<p>Total applicable cost of the construction works: 100,000.- EUR</p> <ul style="list-style-type: none"> <li>- For a completely carried out construction project, the rate of compensation, pursuant to ABG 1975 Articles <a href="#">20.1/23.1.1</a> = 7.5% would result in a compensation for administrative work of: 7,500 -EUR</li> <li>- According to Articles 24.1 and 24.1.1.6 ABG 1975, 65% of 7.5% shall be charged; this results in a rate of compensation of: 100,000 -EUR x 0.075 x 0.65 = 4,875 -EUR</li> <li>- In accordance with Article 24.1.2 ABG 1975, an additional amount from a construction project which was completed up to 90% is assessed as follows: 7,500 -EUR x 0.90 x 0.30 = 2,025 -EUR</li> </ul> <p>This results in a total compensation of: 6,900.- EUR</p> <ul style="list-style-type: none"> <li>- Compensation pursuant to Article 24.2 ABG 1975. If costs of consultants amount to 6,900 -EUR, a total compensation of 6,900 -EUR results.</li> </ul> <p>At costs over 6,900 -EUR to 7,499 -EUR, the compensation shall be determined in the amount to be expended for the consultant(s).</p> <p>At costs of and over 7,500 -EUR, however, only 7,500 -EUR shall be applied as upper limit.</p> <p>The percentages mentioned in the <a href="#">UP re Article 23</a> ABG 1975 shall be given adequate consideration.</p> <p>24.3 An approval by the U.S. Forces for the employment of consultants is not required. At the request of the U.S. Forces, the Bauamt shall furnish the U.S. Forces the justification for the need for consultants and the scope of services to be assigned; as well as comments regarding the qualification of the consultants.</p>	

III. <u>ABG 1975 (U.S.)</u>	Protocol of Signature (PoS / UP), Cover Letter (CL / BglB) and <u>Implementing Instructions (IIs / RiABG)</u>	<u>Notes</u>
<p>24.1.2 If, at the request of the Forces, the execution of any construction works is interrupted or discontinued after commencement of building, the percentage amount, referred to in Article 24.1.1.6, payable to the German authorities shall be augmented by an additional amount to be computed according to the following formula:</p> <p><math>x/y * z = \text{additional amount.}</math></p> <p>x = actual cost of the part of the construction works carried out.</p> <p>y = estimated total applicable cost of the construction works which would have arisen in the event of completion.</p> <p>z = thirty percent (30%) of the full administrative compensation which would have been payable on the basis of the above estimated total cost (y).</p> <p>24.2 The rate of compensation pursuant to Article 24.1 includes the cost of consultants with the percentage rate applicable to the relevant building services. These consultants can only be employed according to the provisions of the RBBau K12. Actual costs, however, exceeding the amount computed according to Article 24.1, shall be added to the compensation to the extent that the total does not exceed the rates which would have been payable according to <a href="#">Article 23</a>.</p>		

III. <u>ABG 1975 (U.S.)</u>	Protocol of Signature (PoS / UP), Cover Letter (CL / BglB) and <u>Implementing Instructions (IIs / RiABG)</u>	<u>Notes</u>
-----------------------------	------------------------------------------------------------------------------------------------------------------	--------------

**SECTION E - PAYMENT OF THE COST OF CONSTRUCTION WORKS, MISCELLANEOUS UNAVOIDABLE COSTS AND COMPENSATION FOR ADMINISTRATIVE WORK**

<p><b>Article 25 [Fund Allocation, Invoicing, Examination by the German Federal Audit Office]</b></p> <p>25.1 Normally the funds required to pay the cost of construction works, including, if necessary, those cases mentioned in <a href="#">Article 18</a> and miscellaneous unavoidable costs, shall be made available to the German authorities in time for payment to be made when due. To this end the German authorities shall transmit to the Forces, at least one month before payment is due, a schedule of the estimated funds required.</p> <p>25.2 If, because of the Forces' budgetary regulations, the necessary funds cannot be placed at the disposal of the German authorities in advance, payment by the Forces may be made after presentation by the German authorities of itemized invoices covering parts of work completed. Provision for the application of this procedure shall be made in the contracts with contractors.</p> <p>25.3 Not later than six months after the take-over of the completed construction works, the German authorities shall give the Forces detailed accounts which will be supplemented by the original copies of all paid bills.</p> <p>25.4 If, in accounting for construction works financed by the Forces the German</p>	<p align="center"><b>PoS - re Article 25.2</b></p> <p>Due to budgetary regulation of the United States, funds normally cannot be placed at the disposal of the German authorities in advance.</p> <p align="center"><b>PoS - re Article 25.5</b></p> <p>The Comptroller General of the United States or any of his duly authorized representatives shall, until the expiration of three years after final payment under this contract and the subcontract hereunder, have access to and the right to examine any directly pertinent books, documents, papers and records of the German authorities involving transactions related to this contract and the subcontract hereunder.</p> <p align="center"><b>IIs - Re Article 25</b></p> <p>25.1 The following procedure shall be applied in the cases mentioned in Article 25.2 ABG 1975 and the UP/[PoS] Re Article 25.2.</p> <p>25.1.1 Upon examination and verification of the contractor invoices, the competent German Agency (e.g. Bauamt) shall forward 2 extra copies of these documents with 6 copies of Form ABG 8 to the U.S. Forces and request the immediate transmission of the required funds to the centrally responsible Federal Cashier's Office (Bundeskasse).</p> <p>25.1.2 The U.S. Forces shall return one copy of Form ABG 8, which is provided with the note of certification, and one copy of the contractor invoice to the competent German Agency (e.g. Bauamt) and transfer the necessary funds or send a corresponding check to the centrally responsible Bundeskasse. The funding transfer document shall include the required control number (with the funding code 8).</p> <p>25.1.3 The Bauamt shall transmit the request to the U.S. Forces (ABG Form 8) together with the order for payment to the responsible</p>	
------------------------------------------------------------------------------------------------------------------------------------------------------------------------------------------------------------------------------------------------------------------------------------------------------------------------------------------------------------------------------------------------------------------------------------------------------------------------------------------------------------------------------------------------------------------------------------------------------------------------------------------------------------------------------------------------------------------------------------------------------------------------------------------------------------------------------------------------------------------------------------------------------------------------------------------------------------------------------------------------------------------------------------------------------------------------------------------------------------------------------------------------------------------------------------------------------------------------------------------------------------------------------------	------------------------------------------------------------------------------------------------------------------------------------------------------------------------------------------------------------------------------------------------------------------------------------------------------------------------------------------------------------------------------------------------------------------------------------------------------------------------------------------------------------------------------------------------------------------------------------------------------------------------------------------------------------------------------------------------------------------------------------------------------------------------------------------------------------------------------------------------------------------------------------------------------------------------------------------------------------------------------------------------------------------------------------------------------------------------------------------------------------------------------------------------------------------------------------------------------------------------------------------------------------------------------------------------------------------------------------------------------------------------------------------------------------------------------------------------------------------------------------------------------------------------------------------------------------------------------------------------------------------------------------------------------------------------------------------------------------------------------------------------------------------------------------------------------	--



III. <u>ABG 1975 (U.S.)</u>	Protocol of Signature (PoS / UP), Cover Letter (CL / BglB) and <u>Implementing Instructions (IIs / RiABG)</u>	<u>Notes</u>
<p>authorities have unexpended balances or credits, they shall refund or credit them to the Forces.</p> <p>25.5 Accounts produced by the German authorities shall be subject to examination by the Federal Audit Office (Bundesrechnungshof), even where the funds involved are national funds of the Forces.</p>	<p>Federal Cashier's Office by indicating the deposit control number for the respective construction project.</p> <p>Following the deposit by the U.S. Forces by indicating the respective control number (with the funding code 8) the amount will be booked to the respective sub-ledger account at the responsible Federal Cashier's Office by way of the payment monitoring procedure (Zahlungsüberwachungsverfahren [ZÜV]). Thereafter, the responsible Federal Cashier's Office will promptly inform the Bauamt (by email) on the receipt of payment.</p> <p>After transmission of the required order for payment by the Bauamt, the payment order will be processed by the responsible Federal Cashier's Office considering the deadlines pursuant to Article 25.1.5 of these Implementing Instructions and the amount due will be paid to the contractor's account.</p> <p>Regularly transmitted HKR account statements <sup>1)</sup> or the HICO dialogue procedure <sup>2)</sup> will serve as confirmation of receipt by the responsible Federal Cashier's Office.</p> <p><sup>1)</sup> HKR-automated procedure for the budgetary cash accounting system of the German federal government  <sup>2)</sup> HICO- budget, information, HKR-information-, online communication system</p> <p>25.1.4 The construction works of the U.S. Forces are financed exclusively with U.S. national funds. Consequently, special time limits apply for payment of construction works provided to the U.S. Forces:</p> <ul style="list-style-type: none"> <li>- up to 30 work days for partial payments, and</li> <li>- up to 72 work days for final payments.</li> </ul> <p>Thereby all German and U.S. agencies involved in the payment procedure are committed to take the steps prescribed by the payment procedure immediately and on short notice and observe the deadlines agreed upon with the contractor.</p> <p>25.1.5 The objective and arithmetical audit of the German authorities and the review of the accounting records by the responsible U.S. agency</p>	

III. <u>ABG 1975 (U.S.)</u>	<u>Protocol of Signature (PoS / UP), Cover Letter (CL / BglB) and Implementing Instructions (IIs / RiABG)</u>	<u>Notes</u>
	<p>as contractually agreed are subject to deadlines that were mutually agreed upon:</p> <p>25.1.5.1 Pertaining to partial payments the Bauamt has up to 10 work days to complete its audit and the U.S. Forces are entitled up to 18 work days for their review as agreed in accordance with terms of contract order and allocation of funds. Thereafter the German authorities shall transfer the amount of the invoice to the account of the contractor within two work days.</p> <p>25.1.5.2 Pertaining to final payments the Bauamt has up to 44 work days to complete its audit and the U.S. Forces are entitled up to 24 work days for their review in accordance with terms of contract order and allocation of funds. Thereafter the German authorities shall transfer the amount of the invoice to the account of the contractor within four work days. Inquiries made by either side will be resolved promptly (by means of dialogue procedure).</p> <p>25.1.5.3 The decisive factors for meeting the deadlines are the date of receipt of the contractor invoice by the Bauamt, by the U.S. Forces and the date of receipt of the funds by the responsible Federal Cashier's Office.</p> <p>25.2 Valid invoices on completed sections of construction works within the meaning of Article 25.2 ABG 1975 are all invoices (partial invoices, final invoices) for which a demand for payment on the part of the contractor has been examined and verified by the Bauamt.</p> <p>25.3 The term "accounting (Abrechnung)" contained in Articles 25.3 and 25.4 ABG 1975 is not identical with the term "Rechnungslegung (rendering of accounts)" used in the German budget law.</p> <p>The detailed accounting (Abrechnung) includes documents which form the basis for several orders for payment, such as contract minutes, contracts, offers, letters of award (copy), confirmations of orders, acceptance certificates, computations of quantities, accounting drafts, records on daily wages, supplementary arrangements, etc. An extra copy of these documents, as well as of the paid invoices shall remain at the competent German authority</p>	

III. <u>ABG 1975 (U.S.)</u>	<b>Protocol of Signature (PoS / UP), Cover Letter (CL / BglB) and Implementing Instructions (IIs / RiABG)</b>	<u>Notes</u>
	<p>(e.g. Bauamt) for examination by the Federal Audit Office and be kept in accordance with RBBau - Section K10.</p> <p>25.4 The review by the Federal Audit Office serves to determine whether the German authorities properly performed the tasks to be accomplished under ABG 1975 and whether the construction services ordered were performed and accounted for in accordance with the provisions of the contract. The Federal Audit Office will hereby consult the responsible Federal Review Offices, as required. At their request, the U.S. Forces shall be informed by the responsible supreme technical Federal agency on the review results achieved by the Federal Audit Office.</p>	
<p> <b><u>Article 26 [Compensation Payment Procedures]</u></b></p> <p>26.1 In the cases of new construction, alterations and extensions, the compensation payable by the Forces to the German authorities shall be paid for each individual construction work after the German authorities have submitted a certificate of completion with an authenticated list of all the final bills payable.</p> <p>26.2 In cases of repair and maintenance; the compensation shall be calculated on the basis of authenticated lists of the expenditure incurred and shall be paid in a lump sum at the end of the accounting year.</p> <p>26.3 In cases to which Articles 26.1 and 26.2 apply, the Forces shall make partial payments, if so requested by the German authorities.</p>	<p style="text-align: center;"><b>IIs - Re Article 26</b></p> <p>26.1 For the fulfilment of the payments obligations in regard to the compensation for administrative work payable to the Federal Ministry of for Transport, Building and Urban Affairs, the competent German authority (e.g. OFD or Bauamt) shall ask the U.S. Forces with a Form ABG 9 for the amounts arising from ABG 1975 and the UP / [PoS].</p> <p>The payments regulations of the U.S. Forces do not admit a deferment of the payable compensation until after the completion of a construction project (Article 26.1 ABG 1975) or until the end of a fiscal year (Article 26.2 ABG 1975). For this reason, additional instalment payments (Article 26.3 ABG 1975) must be made, on-the basis of the estimated chargeable construction costs, in the following phases:</p> <p>26.1.1 for major new construction, alterations and extensions (<a href="#">Article 1.4.2</a> ABG 1975)</p> <ul style="list-style-type: none"> <li>- upon completion of the services specified in <a href="#">Article 7.1.3</a> ABG 1975 (HU-Bau) 20% of the compensation for administrative work in addition to costs for any additional completed services as defined in Articles <a href="#">10.2.3</a> and <a href="#">20.2</a> of these Implementing Instructions minus any previous payments.</li> </ul>	

III. <u>ABG 1975 (U.S.)</u>	<b>Protocol of Signature (PoS / UP), Cover Letter (CL / BglB) and Implementing Instructions (IIs / RiABG)</b>	<u>Notes</u>
26.4 Details of the accounting procedure shall be laid down in the implementing instructions.	<ul style="list-style-type: none"> <li>- upon start of construction (first order - <a href="#">Article 7.1.6</a> ABG 1975) 60% of the compensation for administrative work in addition to costs for any additional completed services as defined in Articles <a href="#">10.2.3</a> and <a href="#">20.2</a> of these Implementing Instructions minus any previous payments.</li> <li>- upon completion of 70% of construction work (<a href="#">Article 7.1.7</a> ABG 1975) 95% of the compensation for administrative work in addition to costs for any additional completed services as defined in Articles <a href="#">10.2.3</a> and <a href="#">20.2</a> of these Implementing Instructions minus any previous payments.</li> </ul> <p>26.1.2 for minor new construction, alterations and extensions (<a href="#">Article 1.4.1</a> ABG 1975) as well as repair and maintenance (<a href="#">Article 1.3</a> ABG 1975)</p> <ul style="list-style-type: none"> <li>- upon conclusion of the services specified in <a href="#">Article 7.1.3</a> ABG 1975 (HU- Bau) 20% of the compensation for administrative work in addition to costs for any additional completed services as defined in Articles <a href="#">10.2.3</a> and <a href="#">20.2</a> of these Implementing Instructions minus any previous payments.</li> <li>- upon conclusion of the services specified in <a href="#">Article 7.1.6</a> ABG 1975 (start of construction) 60% of the compensation for administrative work in addition to costs for any additional completed services as defined in Articles <a href="#">10.2.3</a> and <a href="#">20.2</a> of these Implementing Instructions minus any previous payments.</li> </ul> <p>26.1.3 for major new construction, alterations and extensions (<a href="#">Article 1.4.2</a> ABG 1975), for minor new construction, alterations and extensions (<a href="#">Article 1.4.1</a> ABG 1975) as well as repair and maintenance (<a href="#">Article 1.3</a> ABG 1975), in cases where the design or construction execution is not continued within a six month period due to lack of project funding.</p>	

III. <u>ABG 1975 (U.S.)</u>	<u>Protocol of Signature (PoS / UP), Cover Letter (CL / BglB) and Implementing Instructions (IIs / RiABG)</u>	<u>Notes</u>
	<ul style="list-style-type: none"> <li>- upon completion of the services specified in <a href="#">Article 7.1.2</a> ABG 1975 (KVM- Bau) 5% of the compensation for administrative work in addition to costs for any additional completed services as defined in Articles <a href="#">10.2.3</a> and <a href="#">20.2</a> of these Implementing Instructions.</li> <li>- upon completion of the services specified in <a href="#">Article 7.1.4</a> ABG 1975 (AFU- Bau) 40% of the compensation for administrative work in addition to costs for any additional completed services as defined in Articles <a href="#">10.2.3</a> and <a href="#">20.2</a> of these Implementing Instructions minus any previous payments.</li> <li>- upon completion of the services specified in <a href="#">Article 7.1.5</a> ABG 1975 (tendering) 55% of the compensation for administrative work in addition to costs for any additional completed services as defined in Articles <a href="#">10.2.3</a> and <a href="#">20.2</a> of these Implementing Instructions minus any previous payments.</li> </ul> <p>26.2.1 The requests on Form ABG 9 (6 copies) must include:</p> <ul style="list-style-type: none"> <li>- the control number (with the funding code 9), designation and type of the construction project, a determination of the chargeable costs, the amount of compensation arising therefrom and a determination of the completed additional services as defined in Articles <a href="#">10.2.3</a> and <a href="#">20.2</a> of these Implementing Instructions.</li> <li>- the account to which the compensation for administrative work shall be transferred.</li> <li>- the contractor invoices (2 copies) for additional services carried out according to <a href="#">Article 10</a> of these Implementing Instructions.</li> </ul> <p>26.2.2 The computation of the compensation for administrative work shall be based on the latest approved construction cost (approved ABG 3/ABG 4/ABG 5/ABG 8).</p>	

III. <u>ABG 1975 (U.S.)</u>	<b>Protocol of Signature (PoS / UP), Cover Letter (CL / BglB) and Implementing Instructions (IIs / RiABG)</b>	<u>Notes</u>
	<p>26.2.3 The Bauamt shall transmit the request to the U.S. Forces (Form ABG 9) together with the order for payment to the Federal Cashier's Office by indicating the deposit control number for the respective construction project.</p> <p>26.3 The U.S. Forces shall return one copy of the Form ABG 9 Form provided with the note of certification to the competent German Agency (e.g. Bauamt) and transfer the required funds or forward a corresponding check to the responsible Federal Cashier's Office. The funding transfer document shall include the required control number (with the funding code 9). Inquiries made by either side will be resolved promptly (by means of dialogue).</p>	

III.	<u>ABG 1975 (U.S.)</u>	Protocol of Signature (PoS / UP), Cover Letter (CL / BglB) and <u>Implementing Instructions (IIs / RiABG)</u>	<u>Notes</u>
------	------------------------	------------------------------------------------------------------------------------------------------------------	--------------

**PART III - EXECUTION OF CONSTRUCTION WORKS BY THE FORCES WITH THEIR OWN PERSONNEL OR LABOR EMPLOYED BY THEM OR BY DIRECT CONTRACT  
(DIRECT PROCEDURE)**

**SECTION A - GENERAL**

<p> <b>Article 27 [Allowable Direct Construction Work]</b></p> <p>27.1 The Forces may execute, by means of their own personnel or labor employed by them or by directly awarding contracts to contractors</p> <p>in consultation with the German authorities,</p> <p>27.1.1 repair and maintenance work,</p> <p>27.1.2 construction works requiring special security measures,</p> <p>27.1.3 very minor construction, alterations and extensions up to and including 150,000 Euro,</p> <p>and in agreement with the German Authorities,</p> <p>27.1.4 minor construction, alterations and extensions up to and including 375,000 Euro,</p> <p>27.1.5 exceptionally, construction works in other cases: agreement for the purposes of this Article has been reached that the Forces may carryout construction works for the purposes of training, the execution of which has been included wholly or partly in the schedule of the military construction units under the supervision of the Forces, or construction works</p>	<p align="center"><b>PoS - re Article 27</b></p> <ol style="list-style-type: none"> <li>1. The term "in consultation" as used in Articles 27.1 and 27.2 ABG 1975 means appropriate co-operation between the U.S. Forces and the German authorities.</li> <li>2. The U.S. Secretary of Defense and the Secretaries of the Army, Air Force and Navy may initiate exigent projects. The current limit is \$1,000,000. Such projects, because of their urgent need, are not known at the time of programming required by <a href="#">Article 3</a> of ABG 1975 and may, therefore, not be included in such programming action. If the U.S. Forces so desire, such identified exigent military construction projects as approved by the appropriate Secretary are included in the exceptional cases provided for under <a href="#">Article 49 NATO SOFA</a> and Article 27 of ABG 1975. The German authorities shall take this factor into consideration and will approve such cases for direct procedures unless they can furnish compelling reasons for a contrary conclusion.</li> </ol> <p align="center"><b>IIs - Re Article 27</b></p> <p>27.1 Article 27 defines the cases and conditions under which the U.S. Forces stationed in the Federal Republic of Germany may execute construction projects with their own personnel or by directly awarding contracts to contractors.</p> <p>27.2 In order to ensure the “consultation” within the meaning of Article 27 ABG 1975, the U.S. Forces shall comply with their obligations under <a href="#">Article 1.10</a> ABG 1975 and shall notify the German authorities of their construction projects as follows:</p> <p>27.2.1 The U.S. Forces shall notify the German authorities in writing of the approximate annual costs for maintenance and repair measures to be carried out under Article 27.1.1 ABG 1975.</p>	
-------------------------------------------------------------------------------------------------------------------------------------------------------------------------------------------------------------------------------------------------------------------------------------------------------------------------------------------------------------------------------------------------------------------------------------------------------------------------------------------------------------------------------------------------------------------------------------------------------------------------------------------------------------------------------------------------------------------------------------------------------------------------------------------------------------------------------------------------------------------------------------------------------------------------------------------------------------------------------------------------------------------------------------------------------------------------------------------------------------------	-------------------------------------------------------------------------------------------------------------------------------------------------------------------------------------------------------------------------------------------------------------------------------------------------------------------------------------------------------------------------------------------------------------------------------------------------------------------------------------------------------------------------------------------------------------------------------------------------------------------------------------------------------------------------------------------------------------------------------------------------------------------------------------------------------------------------------------------------------------------------------------------------------------------------------------------------------------------------------------------------------------------------------------------------------------------------------------------------------------------------------------------------------------------------------------------------------------------------------------------------------------------------------------------------------------------------------------------------------------------------------------------------------------------------------------------------------------------------------------------------------------------------------------------------------------------------------------------------------------------------------------------------------------------------------------------------------------------------------------------------------------------------------------------------------------------------------------------------------------------------	--

III. <u>ABG 1975 (U.S.)</u>	<u>Protocol of Signature (PoS / UP), Cover Letter (CL / BglB) and Implementing Instructions (IIs / RiABG)</u>	<u>Notes</u>
<p>involving the integration or installation of equipment such as special communications or weapons systems of the Forces.</p>	<p>27.2.2 The U.S. Forces shall notify the German authorities of construction work to be carried out under Article 27.1.2 ABG 1975 using Form ABG 2. The reply of the German authorities provided for in Part II of Form ABG 2 gives these authorities the opportunity to comment on the intention of the U.S. Forces to carry out works under Article 27.1.2 ABG 1975.</p> <p>27.2.3 The German authorities and the U.S. Forces may conclude a simplified notification procedure, (e.g. information may be provided in master lists or during recurrent meetings) for construction, alterations and extensions carried out under Article 27.1.3 ABG 1975.</p> <p>27.3 For the purposes of obtaining agreement under Articles 27.1.4 and 27.1.5 ABG 1975, the U.S. Forces shall inform the German authorities of their intentions using Form ABG 2, and the German authorities shall inform of their position in Part II of Form ABG 2.</p> <p>27.3.1 In relation to minor new construction, alterations and extensions under Article 27.1.4 ABG 1975, the reply provided for in Part II of Form ABG 2 shall be furnished within a period of 24 work days after receipt by the agency responsible for technical supervision. If the U.S. Forces have not received a reply by the end of this period, they shall be entitled to begin the construction work under the direct procedure in accordance with <a href="#">Part III ABG 1975</a>.</p> <p>27.3.2 In relation to construction works under Article 27.1.5 ABG 1975, the rights and duties of the German authorities under <a href="#">Article 30</a> et seq ABG 1975 shall not be affected.</p> <p>27.3.3 Up to an amount of € 6,000,000 (construction costs für new construction, alterations, and extensions), it is generally incumbent upon the US Armed Forces to determine which measures pursuant to article 27.1.5 ABG 1975 may exceptionally be executed in the direct procedure in other cases. The procedure described in part III of the accelerated procedure (AP) must be applied mutatis mutandis. In all other respects, the provisions of Chapter III ABG 1975, in particular the provision on the cost settlement in Article 38, shall apply unchanged.</p>	





III. <u>ABG 1975 (U.S.)</u>	<b>Protocol of Signature (PoS / UP), Cover Letter (CL / BglB) and Implementing Instructions (IIs / RiABG)</b>	<u>Notes</u>
	<p>Unless there are compelling reasons against the execution in the direct procedure (e. g. high standards for approvals under public law), the Federal Government agrees to execution in the direct procedure.</p> <p>27.3.4 The increase in the value limit will initially apply for a period of 5 years after its introduction. The Parties agree that if the value limit proves inappropriate, it will be adjusted by written agreement in bilateral consultation between the US Armed Forces and the German Government.</p> <p>27.3.5 The possibility existing under article 27.1.5 of the ABG 1975 to apply the direct procedure for construction projects exceeding the amount of € 6,000,000 remains unaffected by this, provided that US gives factual reasons for this and these are understood and recognized by the Federal Government.</p> <p>27.4 The course of the procedure to be applied as a rule under paragraphs 27.2 and 27.3 of these Implementing Instructions is represented schematically in enclosure 2 [Appendix II of this handbook] to these Implementing Instructions. The Bauamt (building authority) shall inform the responsible Federal Institute for Real Estate (Bundesanstalt für Immobilienaufgaben) of the projects of the U.S. Forces by means of a copy of Form ABG 2.</p> <p>27.5 Accommodation and public law approvals are not granted hereby. The views of the German technical agencies will only be obtained within the framework of the procedure laid down in <a href="#">Article 30</a> ABG 1975.</p> <p>27.6 In deviation from Article 27.2 of the PoS / [UP], ABG 1975 the current limit for the initiation of exigent projects is \$1,500,000. If the project is intended solely to correct deficiencies that threaten life, health or safety the current limit is \$3,000,000 in exceptional cases. The German authorities shall take this factor into consideration and will approve such cases for direct procedures unless they can furnish compelling reasons for a contrary conclusion.</p>	
 <p><b><u>Article 28 [Application of German Regulations Pertaining to Direct Construction Work]</u></b></p>	<p><b>IIs - Re Article 28</b></p>	

III. <u>ABG 1975 (U.S.)</u>	Protocol of Signature (PoS / UP), Cover Letter (CL / BglB) and <u>Implementing Instructions (IIs / RiABG)</u>	<u>Notes</u>
<p>In carrying out construction works, the Forces shall respect German building regulations and take into consideration the principles applying in the Federal Republic of Germany regarding public construction contracts, which are reflected in the regulations concerning competition, preferred tenderers, and prices applicable to public contracts.</p>	<p>The rules on the prices applicable to public contracts no longer need to be taken into consideration.</p>	
<p> <b>Article 29 [Project Coordination Procedures]</b></p> <p>29.1 In the case of construction projects which cost more than 150,000 Euro up to and including 375,000 Euro the procedure described in <a href="#">Section B of Part III</a> shall only be applied, if the German authorities so request when the program is coordinated.</p> <p>29.2 Without prejudice to the provisions of <a href="#">Article 3, paragraph 2</a>, construction projects the cost of which does not exceed 150,000 Euro are exempt from the procedure established in <a href="#">Section B of Part III</a>.</p>	<p style="text-align: center;"><b>IIs - Re Article 29</b></p> <p>No comments.</p>	

III. <u>ABG 1975 (U.S.)</u>	Protocol of Signature (PoS / UP), Cover Letter (CL / BglB) and <u>Implementing Instructions (IIs / RiABG)</u>	<u>Notes</u>
-----------------------------	------------------------------------------------------------------------------------------------------------------	--------------

<b>SECTION B - PROCEDURES</b>		
<p><b>◀◀ <u>Article 30 [Participation of German Agencies; Detailed Coordination Procedures]</u></b></p> <p>30.1 In the case of construction works covered by the provisions of <a href="#">Part III</a>, planning may be undertaken by the Forces themselves or they may commission a firm of architects/engineers. Where there is indication that these construction projects are subject to permissions or notifications under public law, the Forces shall involve the authorities competent for Federal building as early as possible. In such cases, it shall be the responsibility of the Forces to prepare the necessary documentation required for requesting permissions and making notifications and to forward these to the authorities competent for Federal building. For the purpose of obtaining permissions or making notifications under public law the principles of <a href="#">Article 53A of the NATO SOFA SA</a> shall apply.</p> <p>30.2 Before the preparation of the Forces' documents equivalent to the "Haushaltsunterlage-Bau" the Forces shall transmit to the Oberfinanzdirektion concerned a general description of the construction works (including the development measures) accompanied by the Forces' documents equivalent to the "Kostenvoranmeldung-Bau". The Forces' documents equivalent to the "Kostenvoranmeldung-Bau" shall consist of an informal explanatory</p>	<p style="text-align: center;"><b>IIs - Re Article 30</b></p> <p>30.1 The transmission provided for in Article 30.2 ABG 1975 of the provisional construction documents in the German language is an absolute requirement in order to allow the agency responsible for technical supervision to become active in accordance with Article 30.3 ABG 1975.</p> <p>30.2 Where a special permit, license or other form of official permission must be obtained under public law, the German authorities shall, in cooperation with the authorities of the U.S. Forces, submit the necessary applications and undertake the relevant administrative and legal procedures. All necessary application documents shall be prepared by the U.S. Forces in the German language and submitted to the German authorities in sufficient quantity for purposes of carrying out the procedure. If requested by the U.S. Forces, the German authorities will provide all necessary application forms in sufficient quantity and assist the forces completing them.</p> <p>30.3 It is in the U.S. Forces' interest, concerning all construction measures subject to permits under public law or notification (Kenntnisgaben), to consult with the German authorities at a very early stage. The decision whether a permit procedure or a comparable procedure related to building law is applicable depends on the respective Federal State building regulations.</p> <p>30.4 If the agency responsible for technical supervision cannot obtain the results of the examination within the agreed time limit it shall inform the U.S. Forces as soon as possible (if necessary by telephone).</p>	

III. <u>ABG 1975 (U.S.)</u>	<u>Protocol of Signature (PoS / UP), Cover Letter (CL / BglB) and Implementing Instructions (IIs / RiABG)</u>	<u>Notes</u>
<p>report, a rough cost estimate, a general location plan (town plan or map survey map with the location of the site marked on it), and a building expert's technical report as to the suitability of the site.</p> <p>30.3 On the basis of these documents, the Oberfinanzdirektion shall consult the specialized German authorities concerned and ascertain within a time-limit agreed by the Forces whether there are any fundamental objections to the project from the point of view of the public interest. The Oberfinanzdirektion shall inform the Forces accordingly and indicate any conditions which should be observed.</p> <p>30.4 If it is necessary to initiate procedures for the purpose of town and country planning, land procurement and/or establishment of a restricted area, the relevant provisions of the NATO SOFA, the SA thereto, the Protocol of Signature to the SA, and the administrative agreements concluded to implement these provisions shall apply.</p> <p>30.5 Upon written request by the Forces, the Oberfinanzdirektion shall arrange for any necessary tree-felling as soon as the details of the construction works concerned have been decided upon.</p>		
<p> <b><u>Article 31 [Observing Conditions Established by the German Authorities]</u></b></p> <p>31.1 During the preparation of the Forces' documents equivalent to the "Haushaltsunterlage- Bau", the Forces</p>	<p><b>IIs - Re Article 31</b></p> <p>The transmission provided for in Article 31.2 ABG 1975 of the provisional construction documents is an absolute requirement in order to allow the agency responsible for technical supervision to become active in accordance with Article 31.3 ABG 1975.</p>	

III. <u>ABG 1975 (U.S.)</u>	Protocol of Signature (PoS / UP), Cover Letter (CL / BglB) and <u>Implementing Instructions (IIs / RiABG)</u>	<u>Notes</u>
<p>may invite the Oberfinanzdirektion to attend discussions on the planned construction works.</p> <p>31.2 The forces shall transmit without delay the documents referred to in Article 31.1 consisting of plans, an explanatory report, a cost estimate, an area calculation and a technical building expert's report, or alternative documents, together with a time schedule and an outline of further details of planning and execution, to the Oberfinanzdirektion.</p> <p>31.3 The Oberfinanzdirektion shall have these documents examined by the competent specialist German authorities to determine whether conditions established in accordance with <a href="#">Article 30.3</a> have been complied with, and whether any other conditions should be observed. The Oberfinanzdirektion shall inform the Forces accordingly within an agreed time-limit.</p> <p>One set of the planning and working documents shall be retained by the Oberfinanzdirektion.</p>		
<p> <b><u>Article 32 [Compliance with Technical Building Codes]</u></b></p> <p>32.1 Applicable German technical regulations shall be respected in the preparation of the structural analysis, reinforcement plans, and thermal and sound-proofing insulation documents.</p>	<p style="text-align: center;"><b>IIs - Re Article 32</b></p> <p>No comments.</p>	



III. <u>ABG 1975 (U.S.)</u>	Protocol of Signature (PoS / UP), Cover Letter (CL / BglB) and <u>Implementing Instructions (IIs / RiABG)</u>	<u>Notes</u>
32.2 The necessary certification of approval of the structural analysis shall be obtained by the Forces.		
<p>◀◀ <b><u>Article 33 [Construction Measures Within and Outside Accommodation]</u></b></p> <p>33.1. Work inside the accommodation concerned may be executed by the Forces themselves or by contractors.</p> <p>33.2. Work outside the accommodation (in particular external development measures) shall be executed by the German authorities concerned, unless they expressly authorize execution by the Forces.</p> <p>Utility services shall thus be brought in by the supply company concerned; permanent telecommunication installations shall be provided by the Federal German Post Office or its approved contractors.</p>	<p style="text-align: center;"><b>IIs - Re Article 33</b></p> <p>No comments.</p>	
<p>◀◀ <b><u>Article 34 [Review by the Regional Finance Office [OFD]]</u></b></p> <p>During the execution of construction works, the Oberfinanzdirektion may examine whether work is proceeding in accordance with the plans and the German regulations, and whether the conditions imposed are being observed and the public interest respected. For this reason representatives of the Oberfinanzdirektion shall have access to a site at any time subject to considerations of military security.</p>	<p style="text-align: center;"><b>IIs - Re Article 34</b></p> <p>No comments.</p>	
<p>◀◀ <b><u>Article 35 [Authority to Issue Directives; Handling of Objections]</u></b></p>	<p style="text-align: center;"><b>IIs - Re Article 35</b></p> <p>No comments.</p>	

III. <u>ABG 1975 (U.S.)</u>	<u>Protocol of Signature (PoS / UP), Cover Letter (CL / BglB) and Implementing Instructions (IIs / RiABG)</u>	<u>Notes</u>
<p>The representatives of the Oberfinanzdirektion are not authorized to give instructions to those engaged in executing the construction project. Any representations shall be made to the Forces and shall be confirmed in writing within five working days after inspection of the building site.</p>		
<p><b>◀◀ <u>Article 36 [Responsibility; Damage Claims; Disputes]</u></b></p> <p>36.1 The Forces shall be responsible for the proper execution of the construction work. By their assistance under this Agreement, the Oberfinanzdirektion and the specialized authorities called in by them shall not assume any responsibility of the Forces.</p> <p>36.2 In the case of claims for damage in connection with construction work, the provisions of Article VIII of the NATO SOFA, Article 41 of the SA NATO SOFA, and the Protocol of Signature thereto, shall apply.</p> <p>36.3 In the case of disputes arising out of contracts, the provisions of Article 44 of the SA NATO SOFA and the provisions of administrative agreements concluded in accordance with that Article shall apply.</p>	<p style="text-align: center;"><b>IIs - Re Article 36</b></p> <p>The administrative agreements concluded between the Federal Ministry of Finance and the U.S. Forces to Article VIII NATO SOFA in connection with Article 41 SA NATO SOFA and to Article 44 SA NATO SOFA are published in Supplement 5/75 to the Federal Gazette No. 25 of 6 February 1975. This publication of the administrative agreements concluded with the Sending States Forces and the International SHAPE Headquarters regarding the payment of damages was supplemented on 12 November 1980 (Federal Gazette No. 223 of 29 November 1980) and on 31 October 2001 (Federal Gazette No. 60a of 27 March 2002).</p>	
<p><b>◀◀ <u>Article 37 [Final Inspection; Correction of Deficiencies Noted by the OFD]</u></b></p> <p>37.1 Upon completion of construction works, a joint final inspection shall be carried out. The date appropriate for this inspection shall be made known to the</p>	<p style="text-align: center;"><b>IIs - Re Article 37</b></p> <p>37.1 The agency responsible for technical supervision shall inform the responsible Federal Institute for Real Estate (Bundesanstalt für Immobilienaufgaben) of the date of the final acceptance inspection made known by the U.S. Forces.</p>	

III. <u>ABG 1975 (U.S.)</u>	<b>Protocol of Signature (PoS / UP), Cover Letter (CL / BglB) and Implementing Instructions (IIs / RiABG)</b>	<u>Notes</u>
<p>Oberfinanzdirektion in good time. The Oberfinanzdirektion shall record the results of the final inspection and shall send one copy of the record to the Forces. The Forces shall also record the result of the final inspection and shall, at a time to be agreed at the final inspection, make available to the Oberfinanzdirektion a copy of that record and the plans showing actual construction work carried out.</p> <p>37.2 If it is considered necessary for reasons of public interest to remedy any defect, the Oberfinanzdirektion shall notify the Forces in writing within five working days. The Forces shall ensure speedy remedial action and shall inform the Oberfinanzdirektion accordingly.</p>	<p>37.2 In deviation from Art. 37.1 ABG 1975 the results of the final inspection will be recorded in a joint memorandum of the U.S. Forces and the agency responsible for technical supervision using Form ABG 7B. The memorandum will be distributed by the agency responsible for technical supervision as shown in the flow chart attached to these Implementing Instructions.</p>	
<p> <b><u>Article 38 [Cost Settlements]</u></b></p> <p>The forces shall not be charged for the services of the Oberfinanzdirektion. In so far as fees and costs arise through the calling-in of other German authorities and agencies in agreement with the Forces, the funds shall be provided by the Forces where these services are not of the type to be provided free by the German authorities in accordance with the NATO SOFA and the SA thereto.</p>	<p><b>IIs - Re Article 38</b></p> <p>The cost settlement as provided in Article 38 ABG 1975 is based on the fundamental idea of the entire direct procedure which is laid down in <a href="#">Part III</a>, according to which the German authorities provide in these cases only official assistance for the U.S. Forces and the U.S. Forces execute the construction project in their own name and responsibility.</p>	



III.	<u>ABG 1975 (U.S.)</u>	<b>Protocol of Signature (PoS / UP), Cover Letter (CL / BglB) and Implementing Instructions (IIs / RiABG)</b>	<u>Notes</u>
------	------------------------	-------------------------------------------------------------------------------------------------------------------	--------------

<b>PART IV - TRANSITIONAL AND CONCLUDING PROVISIONS</b>			
	<b><u>Article 39 [Authority of Implementing Instructions]</u></b>	<b>PoS - re Article 39</b>	
Implementing instructions for this Agreement shall be established bilaterally between the Federal Minister for Regional Planning, Building and Urban Development and the competent authorities of the Forces. Unless otherwise agreed, existing implementing instructions to the procedures under previous agreements shall remain in force until superseded, in so far as they do not conflict with this Agreement.	<ol style="list-style-type: none"> <li>1. For the performance of construction projects for the U.S. Forces, the German authorities will take into account the principles of United States law contained in <a href="#">Annex A [PoS / UP]</a>, insofar as their application is not restricted by international agreements, for example the SA NATO SOFA.</li> <li>2. The ABG Form 3, as provided for in the implementing instructions, upon execution by the U.S. Forces, shall operate as an order against this agreement.</li> </ol>	<b>IIs - Re Article 39</b>	
	<b><u>Article 40 [Amendments to Agreement; Consultations]</u></b>	<b>IIs - Re Article 40</b>	
<p>40.1 At the request of either party this Agreement may be amended by mutual agreement.</p> <p>40.2 Differences of opinion in regard to the interpretation and application of this Agreement, matters not covered by this Agreement, or modifications of certain provisions of this Agreement considered justifiable as a result of exceptional circumstances shall be subject to negotiations between the Federal Minister for Regional Planning, Building and Urban Development and the authorities of the Forces.</p>	No Comments.	<b>IIs - Re Article 40</b>	

III. <u>ABG 1975 (U.S.)</u>	<b>Protocol of Signature (PoS / UP), Cover Letter (CL / BglB) and Implementing Instructions (IIs / RiABG)</b>	<u>Notes</u>
-----------------------------	-------------------------------------------------------------------------------------------------------------------	--------------

<p><b>◀◀ <u>Article 41  Effective Date of Agreement; German and English Text Equally Effective </u></b></p> <p>This Agreement shall enter into on the first day of the month following the month in which it is signed by the second Contracting Party. At the same time, the current administrative agreements listed in the covering letter to this Agreement shall cease to have effect.</p> <p>This Agreement has been drawn up in the German and English languages. Both texts being equally effective.</p>	<p><b>CL - re Article 41</b></p> <ul style="list-style-type: none"> <li>- ABG 1975 applies to all construction projects for which the first letter of request (ABG Form 3) or a notification of projects under the direct procedure (ABG Form 2) were transmitted to the German authorities after the effective date of that Administrative Agreement.</li> <li>- Construction projects, for which an order was placed with the German authorities in accordance with the [former] Dollar Construction Contract 1956/61 and prior to the coming into force of the Administrative Agreement ABG 1975, shall be accomplished and accounted in compliance with that Contract and the then applicable implementing agreements.</li> <li>- Construction projects which were started prior to the effective date of ABG 1975 under the direct procedure or a special procedural agreement are likewise not affected by the new provisions.</li> </ul>	
------------------------------------------------------------------------------------------------------------------------------------------------------------------------------------------------------------------------------------------------------------------------------------------------------------------------------------------------------------------------------------------------------------------------------------------------------------------------------------------------------------------	-------------------------------------------------------------------------------------------------------------------------------------------------------------------------------------------------------------------------------------------------------------------------------------------------------------------------------------------------------------------------------------------------------------------------------------------------------------------------------------------------------------------------------------------------------------------------------------------------------------------------------------------------------------------------------------------------------------------------------------------------------------------------------------------------------------------------------------------------------------------------------------------------------------------------------------------------	--

**ANNEX A TO THE PROTOCOL OF SIGNATURE (PoS / UP) TO ABG 1975**

**1. United States Officials not to Benefit**

No member of the Congress of the United States, or resident commissioner of the United States, shall be admitted to any share or part of this contract, or to any benefit that may arise therefrom; but this provision shall not be construed to extend to this contract if made with cooperation for its general benefit.

**2. Covenant against Contingent Fees**

The German authorities warrant that no person or selling agency has been employed or retained to solicit or secure this contract upon an agreement or understanding for a commission, percentage, brokerage, or contingent fee, except bona fide employees or bona fide established commercial or selling agencies maintained by the German authorities for the purpose of securing business. For breach or violation of this warranty, the United States Government shall have the right to annul this contract without liability or, in its discretion, to deduct from the contract price or consideration the full amount of such condition, percentage, brokerage, or contingent fee.

**3. Gratuities**

- a) The United States may, by written notice to the Contractor, terminate the right of the Contractor to proceed under this contract if it is found, after notice and hearing, by the Secretary or his duly authorized representative, that gratuities (in the form of entertainment, gifts, or otherwise) were offered or given by the Contractor, or any agent or representative of the Contractor, to any officer or employee of the United States with a view toward securing a contract or securing favorable treatment with respect to the awarding or amending, or the making of any determinations with respect to the performing of such contract; provided, that the existence of such facts upon which the Secretary or his duly authorized representative make such findings shall be in issue and may be reviewed in any competent court.
- b) In the event this contract is terminated as provided in paragraph (a) hereof, the United States shall be entitled
  - (i) to pursue the same remedies against the Contractor as it could pursue in the event of a breach of the contract by the Contractor, and
  - (ii) as a penalty in addition to any other damages to which it may be entitled by law, to exemplary damages in an amount (as determined by the Secretary or his duly authorized representative) which shall not be less than three or more times the costs incurred by the Contractor in providing any such gratuities to any such officer or employee.

**4. Cost plus a percentage of cost (Selbstkostenerstattungs-verträge)**

**ANNEX A TO THE PROTOCOL OF SIGNATURE (PoS / UP) TO ABG 1975**

The German authorities will not enter into any contracts on behalf of the United States on the basis of cost plus a percentage of cost.

*Current Electronic Versions can be downloaded at [www.abg-plus.de/abg2/ebuecher/abg\\_us/downloadber.htm](http://www.abg-plus.de/abg2/ebuecher/abg_us/downloadber.htm)*

**APPENDIX 1**  
**ABG 1975 FORMS**

From / Abs.: Adress of US Forces Agency / Anschrift der Behörde der US-Streitkräfte

To /	Bundesministerium für Verkehr, Bau und Stadtentwicklung, Bonn	1	copies / fach
An:	Bundesministerium der Verteidigung, Bonn	3	copies / fach
Info /	Bundesanstalt für Immobilienaufgaben, Bonn	1	copy / fach
nachr.:	Landesministerium	1	copy / fach
	Fachaufsicht führende Ebene (FfE)	3	copies / fach

**Program of Construction Projects for the US Forces  
in the Federal Republic of Germany (Article 3.1 ABG 1975) /  
Programm der Baumaßnahmen für die US-Streitkräfte in der  
Bundesrepublik Deutschland (Artikel 3.1 ABG 1975)**

<b>ABG 1975/ABG 1</b>
<b>Cover Sheet/Deckblatt</b>

Program years / Programmjahre:

Date / Datum:

Itemized list see attachment/number of pages in attachment /  
Einzelaufstellung siehe Anlage/Seitenanzahl:

See column / siehe Spalte:	Explanation of columns in itemized list (attachment) / Erläuterungen zu den Spalten der Einzelaufstellung (Anlage):
<b>e)</b>	<p><b>Category of work / Kategorie der Baumaßnahme:</b></p> <p><b>A</b> Construction projects with cost exceeding Euro 150.000 (each specified) / Baumaßnahmen über Euro 150.000 im Einzelfall gesondert aufgeführt</p> <p><b>B</b> Construction projects with cost not exceeding Euro 150.000 each specified listed together in accordance with the location - indirect procedure only / Baumaßnahmen bis Euro 150.000 im Einzelfall gemeinsam nach Standorten aufgeführt - nur Auftragsbau –</p> <p><b>C</b> Repair and/or maintenance work / Instandsetzung/Instandhaltungsarbeiten</p> <p><b>D</b> Other direct construction projects where permissions or notifications under German public law may be necessary (see comments to Article 3.3.1) / Übrige Truppenbaumaßnahmen, bei denen Genehmigungen oder Kenntnissgaben ggf. erforderlich sind (vgl. Ausführungen zu Art. 3.3.1)</p>
<b>f)</b>	Description of work using supplemental sheet if needed / Beschreibung ggf. mit Beiblatt
<b>h)</b>	Indirect project (I)/Direct project (D)/Note: in case of direct projects include reference to relevant subparagraph of the Article 27 ABG 1975 of the Implement Instructions in column n) / Auftragsbaumaßnahmen (I)/Truppenbaumaßnahmen (D)/Anmerkung: Bei Truppenbaumaßnahmen auf den entschließigen Absatz von Artikel 27 ABG 1975 der Ausführungsrichtlinie in Spalte n) verweisen.
<b>j)</b>	Estimated costs are for year of authorized construction funding / Die geschätzten Kosten werden für das genehmigte Programmjahr bereit gestellt.
<b>k – m)</b>	Planned to be executed (Mo/Yr) / Geplante Durchführung (Monat/Jahr) :
<b>k)</b>	Start of process is the estimated date of first request (ABG 3) or date of letter of intent (ABG 2) / Verfahrensbeginn ist der voraussichtliche Zeitpunkt der ersten Anforderung (ABG 3) oder der Benachrichtigung (ABG 2)
<b>l)</b>	Estimated construction start date (Mo/Yr) / Voraussichtlicher Baubeginn (Monat/Jahr)
<b>m)</b>	Estimated construction completion date (Mo/Yr) / Voraussichtliche Fertigstellung der Baumaßnahmen (Monat/Jahr)
<b>n)</b>	Reason for Direct (Ref. to Art. 27 ABG 1975) / Begründung für Truppenbau (Bezug auf Art. 27 ABG 1975)

**Program of Construction Projects for the US Forces in the Federal Republic of Germany /  
Programm der Baumaßnahmen für die US-Streitkräfte in der Bundesrepublik Deutschland**

**ABG 1975/ABG 1  
Attachment/Anlage**

No. / Nr.	FIE (b)	Installation / Liegenschaft (c)	Location / Standort (d)	Cate- gory of Work / Kate- gorie (e)	Description / Beschreibung (f)	Project No. / Projekt- Nr. (g)	Indirect/ Direct / Auftrags-/ Truppen- bau (h)	Estimated Cost / Geschätzte Kosten in € 1.000 (i)	Year / Jahr (j)	Planned to be executed (Mo/Yr) / Geplante Durchführung (Monat/Jahr)			Remarks / Bemerkungen  Reason for Direct (Ref. to Art. 27 ABG 1975) / Begründung für Truppenbau (Bezug auf Art. 27 ABG 1975) (n)
										Start of Process / Verfahrens- beginn (k)	Construc- tion Start / Baubeginn (l)	Completion / Fertig- stellung (m)	

From / Abs.: Adress of US Forces Agency / Anschrift der Behörde der US-Streitkräfte

- |                 |                          |                                                               |   |               |
|-----------------|--------------------------|---------------------------------------------------------------|---|---------------|
| To / An:        | <input type="checkbox"/> | Bundesministerium für Verkehr, Bau und Stadtentwicklung, Bonn | 8 | copies / fach |
|                 | <input type="checkbox"/> | Bundesministerium der Verteidigung, Bonn                      | 8 | copies / fach |
|                 | <input type="checkbox"/> | Fachaufsicht führende Ebene (FfE)                             |   | copies / fach |
|                 | <input type="checkbox"/> | Bauamt                                                        |   | copies / fach |
| Info. / nachr.: | <input type="checkbox"/> | Landesministerium                                             |   | copy / fach   |
|                 | <input type="checkbox"/> | Fachaufsicht führende Ebene (FfE)                             |   | copies / fach |
|                 | <input type="checkbox"/> | Bauamt                                                        |   | copy / fach   |
|                 | <input type="checkbox"/> | Bundesanstalt für Immobilienaufgaben                          |   | copy / fach   |

**Letter of Intent for Direct Procedure (Article 27 ABG 1975) /  
Benachrichtigung über Vorhaben im Truppenbauverfahren  
(Artikel 27 ABG 1975)**

**ABG 1975/ABG 2**

Reference / Az.:

Location / Ort:

Installation/Property / Liegenschaft:

Title / Bezeichnung:

Type of Construction / Art der Baumaßnahme:

Estimated Cost / Geschätzte Kosten: EURO

Project No. / Projekt Nr.

Contract No. / Vertrag Nr.:

**Part I / Teil I**

1. The US Forces authorities intend to proceed with the a/m construction work according to ABG 1975, Part III with reference to / Die Baubehörden der US-Streitkräfte beabsichtigten o.a. Baumaßnahme nach ABG 1975, Kap. III durchzuführen unter Hinweis auf:
  - 1.1  27.1.1  27.1.2  27.1.3  27.1.4  27.1.5
  - 1.2  PS to Article 27 paragraph 2 / Nr. 2 UP zu Artikel 27
  - 1.3  By their own personnel or employed labor / Mit eigenen Kräften
  - 1.4  By direct award to contractors / Durch unmittelbare Vergabe an Unternehmer
2.  The enclosed supporting documentation is provided for the purpose of the German authorities to obtain permissions and make notifications according to ABG 1975 Article 30.1 for work that falls under 27.1.1 or 27.1.3 in para 1.1 above. / Die beigefügten zusätzlichen Unterlagen werden zur Verfügung gestellt, um es den deutschen Behörden zu ermöglichen, für alle Arbeiten, die unter 27.1.1 oder 27.1.3 in Ziffer 1.1 fallen, gemäß Artikel 30.1 ABG 1975 Genehmigungen einzuholen und Kenntnissgaben vorzunehmen.
3.  A suitable site is available / Ein geeigneter Bauplatz steht zur Verfügung.  
 A suitable site will have to be made available / Ein geeigneter Bauplatz ist noch zur Verfügung zu stellen.
4.  The construction work is included in ABG 1: / Dated / vom for the FY / für das Rj. under No. / unter Nr.  
Die Baumaßnahme ist im Bauprogramm ABG 1 enthalten:  
 The construction work is not included in ABG 1 / Die Baumaßnahme ist im Bauprogramm ABG 1 nicht enthalten.
5.  Description of construction work (short form) and site plan draft are enclosed. / Baubeschreibung (Kurzform) und Lageplanskizze sind beigefügt.
6.  Remarks / Bemerkungen:

Name / Name	Title / Dienstbezeichnung	Signature / Unterschrift	Date / Datum
-------------	---------------------------	--------------------------	--------------

**Teil II / Part II (gilt nur für Arbeiten, die unter 27.1.2, 27.1.4 oder 27.1.5 in obiger Ziffer 1.1 fallen) /  
(only applicable for work that falls under 27.1.2, 27.1.4 or 27.1.5 in para 1.1 above)**

Abs. / From: Zuständige deutsche Behörde / Competent German Authority

- 7.1  Gegen das Truppenbauverfahren bestehen keine Bedenken bei/ohne\* Anwendung des in Kap. III, Abschnitt B der ABG 1975 beschriebenen Verfahrens. / There are no objections to the use of direct procedure in this case with/without\* application of the procedure described in section B of part III ABG 1975.
- 7.2  Gegen das Truppenbauverfahren bestehen Bedenken / There are objections to the use of the direct procedure.
- 7.3  Bemerkung siehe heutiges Schreiben / Remarks see today's letter.

Name / Name	Dienstbezeichnung / Title	Unterschrift / Signature	Datum / Date
-------------	---------------------------	--------------------------	--------------

\* nicht zutreffendes bitte streichen



From /  
Abs.:

To / An:	<input type="checkbox"/> Bundesministerium für Verkehr, Bau und Stadtentwicklung, Bonn	8	copies / fach
	<input type="checkbox"/> Bundesministerium der Verteidigung, Bonn	8	copies / fach
	<input type="checkbox"/> Fachaufsicht führende Ebene (FfE)		copies / fach
	<input type="checkbox"/> Bauamt		copies / fach
Info. / nachr.:	<input type="checkbox"/> Landesministerium		copy / fach
	<input type="checkbox"/> Fachaufsicht führende Ebene (FfE)		copies / fach
	<input type="checkbox"/> Bauamt		copy / fach

**Request-/Approval-/Award-Document (Article 10 ABG 1975) /  
Anforderungs-/Zustimmungs-/Auftrags-Dokument (Artikel 10 ABG 1975)**

**ABG 1975/ABG 3**

Reference / Az.:

US - Project No. /  
US - Projekt Nr.:

Location / Ort:

Installation/Property / Liegenschaft:

ABG 3 - Contract No. /  
ABG 3 - Vertrags-Nr.:

Title / Bezeichnung:

Type of Construction /

Art der Baumaßnahme:

ABG 3 - Modification No. /  
ABG 3 - Nachtrags-Nr.:

- New Construction, alterations and extensions (Article 1.4 ABG 1975) /  
Neu-, Um- und Erweiterungsbauten (Art. 1.4 ABG 1975)
- Repair and Maintenance (Article 1.3 ABG 1975) /  
Instandsetzung und Instandhaltung (Art. 1.3 ABG 1975)

Total Estimated Construction Cost / Geschätzte Baukosten:

EURO

a) Estimated Cost of new construction, alterations and extensions (including  
administrative compensation (VKE)) /  
Geschätzte Kosten für Neu-, Um- und Erweiterungsbauten (einschließlich VKE)

EURO

compensation for administrative work at 5.6% pursuant to Article 23.1.2/PS ABG  
1975 re Article 23 / VKE 5,6% nach Art. 23.1.2 ABG 1975/UP ABG 1975 zu Art. 23

EURO

compensation for administrative work at 7.5% pursuant to Article 23.1.1/PS ABG  
1975 re Article 23 / VKE 7,5% nach Art. 23.1.1 ABG 1975/UP ABG 1975 zu Art. 23

EURO

b) Estimated Cost of repair and maintenance (including compensation for administrative  
work at 7.5% pursuant to Article 23.1.1/PS re Article 23 ABG 1975) /  
Geschätzte Kosten für Instandsetzung und Instandhaltung (einschließlich VKE 7,5%  
nach Art. 23.1.1/UP zu Art. 23 ABG 1975)

EURO

Tentative Construction start date of /  
geplanter Baubeginn:

Tentative Completion date of /  
geplanter Fertigstellungstermin:

Remarks / Bemerkungen

Forces Internal Accounting Data / Für interne Buchungszwecke der Streitkräfte:

--

Part I / Teil I

1.  A suitable site is available / Ein geeigneter Bauplatz steht zur Verfügung.  
 A suitable site will have to be made available / Ein geeigneter Bauplatz ist noch zur Verfügung zu stellen.
  
2. Funds budgeted (Article 12.1 ABG 1975) / im Haushalt bereitgestellte Mittel (Art. 12.1 ABG 1975) EURO  
Amount of funds budgeted means the amount of the estimated construction costs including the compensation of administrative costs, fees and all additional services /  
Unter der Höhe der bereitgestellten Mittel ist der Betrag der veranschlagten Baukosten einschließlich der Verwaltungskostenerstattung (VKE), der Gebühren, sowie alle Sonderleistungen zu verstehen.
  
3. Available funds (Article 12.2 ABG 1975) including costs for fees and additional services / Verfügbarer Betrag (Art. 12.2 ABG 1975) einschließlich Verwaltungsentschädigung (VKE) und Sonderleistungen. EURO
  
4. The additional services are included in the estimated cost in the amount of / Die Sonderleistungen sind in den geschätzten Kosten enthalten mit einem Betrag von EURO
  
5. In accordance with Article 10 ABG 1975 we request and/or approve the following services described in Article 7 ABG 1975 /  
Nach Art. 10 ABG 1975 erteilen wir für nachfolgend bezeichnete und in Art. 7 ABG 1975 beschriebenen Leistungen:  
Request / Anforderung:  7.1.2     7.1.3     7.1.4     7.1.5     7.1.6     7.1.7  

KVM-Bau-	HU-Bau-	AFU-Bau-	Tender action / Ausschreibung	Contract award / Auftragsvergabe	Execution / Bauausführung
----------	---------	----------	----------------------------------	-------------------------------------	------------------------------

  
Approval / Zustimmung\*:  7.1.2     7.1.3     7.1.4

\*In lieu of using the ABG Form 3 for approval of design services that fall under Articles 7.1.2 and 7.1.3 ABG 1975, approval may be granted by letter from the Contracting Officer or his/her authorized representative. For design services that fall under Article 7.1.4 ABG 1975 approval must be granted on the ABG Form 3. /

Anstelle der Zustimmung zu den Leistungen nach Art. 7.1.2 und 7.1.3 ABG 1975 mit Formblatt ABG 3, kann die Zustimmung auch in schriftlicher Form durch den US-Beschaffungsbeamten oder dessen Vertreter erfolgen. Für Leistungen nach 7.1.4 ABG 1975 muss die Zustimmung grundsätzlich mit Formblatt ABG 3 erfolgen.

In cases where the US orders all services from 7.1.2 through 7.1.7 at once (i.e. estimated basis contract), approval of designs (7.1.2 through 7.1.4) is deemed given: however, the US may still provide design review comments for each design submission, if provided within a maximum of 24 workdays after each design submission. If the approved estimated construction costs will be exceeded, then formal approval of the US Forces must be obtained (Re Article 10.2.4). /

Falls die US-Streitkräfte alle Leistungen von 7.1.2 bis 7.1.7 gleichzeitig beauftragen, (d.h. Vertrag auf Grundlage der geschätzten Kosten), gilt die Zustimmung zur Planung als erteilt (7.1.2 bis 7.1.4). Die US-Streitkräfte dürfen eine Stellungnahme zur jeweiligen Planungsvorlage vorlegen, wenn dies innerhalb max. 24 Werktagen erfolgt. Bei Überschreitung der bisher genehmigten geschätzten Baukosten ist eine formale Zustimmung durch die US-Streitkräfte erforderlich (zu Art.10.2.4).

6. This request is based on the following enclosed documents: /  
Der Anforderung werden folgende Unterlagen zugrunde gelegt:  
 Description of construction work (Article 11 ABG 1975) / Baubeschreibung (Art. 11 ABG 1975)  
 Documents prepared by the Forces (Title/Date) (Article 4.5 ABG 1975) /  
Von den Streitkräften gefertigte Unterlagen (Titel der Unterlage/Bearbeitungsstand) (Art. 4.5 ABG 1975)  
(1)  
(2)  
(3)  
 Other Documentation (Title/Date) / weitere Unterlagen (Titel der Unterlage/Bearbeitungsstand)  
(1)  
(2)  
(3)
  
7. Remarks / Bemerkungen:

Current Electronic Versions can be downloaded at [www.abg-plus.de/abg2/ebuecher/abg\\_us/downloadber.htm](http://www.abg-plus.de/abg2/ebuecher/abg_us/downloadber.htm)

8. Issued by / Erteilt durch:

For the United States of America / Für die Vereinigten Staaten von Amerika:

---

Name / Name	Title / Dienstbezeichnung	Signature / Unterschrift	Date / Datum
-------------	---------------------------	--------------------------	--------------

**Teil II / Part II**

Abs./ From: Zuständige deutsche Behörde / Appropriate German Authority

9. Angenommen / Accepted:

Bemerkungen / Remarks:

---

Name / Name	Dienstbezeichnung / Title	Unterschrift / Signature	Datum / Date
-------------	---------------------------	--------------------------	--------------

Abs. / (zuständige deutsche Behörde) / An / (Address of the US Forces Authority) / 5 fach / copies  
 From: (Appropriate German Authority) To: (Anschrift der Behörde der US-Streitkräfte)

From / (Address of the US Forces Authority) / To / (zuständige deutsche Behörde) / 2 copies / fach  
 Abs.: (Anschrift der Behörde der US-Streitkräfte) An: (Appropriate German Authority)

**Angebotsannahme (Artikel 7.1.6 ABG 1975) /  
 Tender Acceptance Form (Article 7.1.6 ABG 1975)**

**ABG 1975/ABG 4**

Az. / Reference:	US - Projekt Nr. / US - Project No.:
Ort / Location:	
Liegenschaft / Installation/Property:	ABG 3 - Vertrags Nr. / ABG 3 - Contract No.:
Bezeichnung / Title:	lfd. ABG 4 - Nr. / ABG 4 Sequence No.:
Art der Baumaßnahme / Type of Construction:	

Geschätzte Kosten / Estimated Cost: EURO

**Part I / Teil I**

Vergabevorschlag einschließlich wirtschaftlicher und fachtechnischer Stellungnahmen (Art. 7.1.5 ABG 1975) /  
 Recommendation for contract award including economic and technical evaluations (Article 7.1.5 ABG 1975)

1. Ablauf der Zuschlagsfrist /  
Tender Expiration Date:
2. Trade / Fachlos

	Firma / Firm:	Angebotssumme (ohne USt.) / Amount of Tender (excl. VAT)	
		bei Eröffnung / Original (Euro)	nachgerechnet / corrected (Euro)
1.			
2.			
3.			
4.			
5.			
6.			
7.			
8.			
9.			
10.			

3. Anlagen / Enclosures:  
 Abschriften von / Copies of  
 Preisgegenüberstellung (Art. 7.1.5.2 ABG 1975) / Comparative price analysis (Article 7.1.5.2 ABG 1975) fach /  
copies  
 Zur Annahme empfohlenes Angebot mit Preisen (Art. 7.1.5.3 ABG 1975) / Recommended tender documents with prices (Article 7.1.5.3 ABG 1975) fach /  
copies

Current Electronic Versions can be downloaded at [www.abg-plus.de/abg2/ebuecher/abg\\_us/downloadber.htm](http://www.abg-plus.de/abg2/ebuecher/abg_us/downloadber.htm)

Leistungsverzeichnis des vorgeschlagenen Auftragnehmers mit Preisen (Art. 7.1.5.4 ABG 1975) / fach /  
Contract Specifications from recommended contractor with prices (Article 7.1.5.4 ABG 1975) copies

Vertragsrechtliche- und fachtechnische Stellungnahme der Angebote (Art. 7.1.5.4 ABG 1975) / fach /  
Technical and contractual evaluation of proposals (Article 7.1.5.4 ABG 1975) copies

4. Abweichungen in den Angebotsunterlagen von den zuletzt anerkannten Unterlagen  bestehen/  bestehen nicht.  
Nebenangebote sind besonders gekennzeichnet. / There are  deviations/  no deviations in the tender documents  
from the latest approved documents. Alternative tenders are specially marked.

Es wird empfohlen, das Angebot Nr.: der Firma: anzunehmen. /  
It is re-commended that the noted tender serial No.: from the noted firm: be accepted.

5. Begründung des Vergabevorschlags / Reasons for the proposed award:

---

Name / Name	Dienstbezeichnung / Title	Unterschrift / Signature	Datum / Date
-------------	---------------------------	--------------------------	--------------

#### Part II / Teil II

6. Acceptance of tender as recommended is agreed and contract amounts are available (Article 12.3 ABG 1975). /  
Der Annahme des Angebots wird wie empfohlen zugestimmt, und die erforderlichen Ausgabemittel stehen zur  
Verfügung (Art. 12.3 ABG 1975).

7. Remarks / Bemerkungen:

8. Except as provided herein, all terms and conditions of the basic order (ABG 3) shall remain in full force and effect. /  
Mit Ausnahme der hierin aufgeführten Änderungen bleiben alle Bedingungen des Auftrages (ABG 3) voll wirksam.

Issued by / Erteilt durch:

For the United States of America / Für die Vereinigten Staaten von Amerika:

---

Name / Name	Title / Dienstbezeichnung	Signature / Unterschrift	Date / Datum
-------------	---------------------------	--------------------------	--------------

Forces Internal Accounting Data / Für interne Buchungszwecke der Streitkräfte:

Abs. / (zuständige deutsche Behörde) / An / (Anschrift der Behörde der US-Streitkräfte) / 5 fach / copies  
 From: (Appropriate German Authority) To: (Address of the US Forces Authority)

From / (Address of the US Forces Authority) / To / (Appropriate German Authority) / 2 copies / fach  
 Abs.: (Anschrift der Behörde der US-Streitkräfte) An: (zuständige deutsche Behörde)

<b>Änderungsdokument (Artikel 12 ABG 1975) / Change Order Document (Article 12 ABG 1975)</b>	<b>ABG 1975/ABG 5</b>
--------------------------------------------------------------------------------------------------	-----------------------

- Änderungsanforderung auf Basis geschätzter Kosten und Terminänderungen /  
Change Request based on estimated costs and revised completion date  
(Estimated Request)
- Geprüfte und mit dem Auftragnehmer abgestimmte Änderungsanforderung /  
Change Request based on proposal negotiated between Bauamt and contractor  
(Negotiated Request)

Nr. / No.	
Az. / Reference:	US - Project-Nr. / US - Projekt No.:
Ort / Location:	
Liegenschaft / Installation/Property:	ABG 3 - Vertrags-Nr. / ABG 3 - Contract No.:
Bezeichnung / Title:	Ifd. ABG 4 - Nr. / ABG 4 Sequence No.:
Art der Baumaßnahme / Type of Construction:	Bauamt Nachtrags - Nr. (NT - Nr.) / Bauamt Change Request No.:

**Teil I / Part I**  
 Änderungsanforderung / Change Request

1. Art der Änderung / Type of Change
  - Mengenänderung / Quantity change
  - Leistungsänderung / Alteration of Work
  - Andere / Others
2. Auswirkungen der Änderung / Impact of change
  - Änderung der Gesamtkosten / Change of total cost
  - Voraussichtliche Änderungen der Termine (vgl. auch 7.1) / Expected change to construction schedule (see 7.1)
  - Andere Auswirkungen (z.B. Vertragsstrafen, etc. - Erklärung ist beigefügt) / Other impacts (e.g. liquidated damages, etc. - explanation is attached)
3. Ursache der Änderung / Cause of Change
  - Anforderung gemäß ABG 5A / Request in accordance with ABG 5A
  - Örtl. Gegebenheiten / Differing site conditions
  - Wetter / Weather
  - Dritte, Behörden / Third party, authorities
  - Andere (z.B. Planungsdefizite, etc. - Erklärung ist beigefügt) / Others (e.g. Design Defencies, etc. - explanation is attached)
4. Kosten der Änderungen / Changes to contract costs
 

4.1 Summe der bisher von den US-Streitkräften genehmigten Änderungen / Cost of previous US approved changes	EURO
4.2 Summe der bisher vorgelegten und noch nicht von den US-Streitkräften genehmigten Änderungen / Cost of previously submitted change requests pending US approval	EURO
4.3 Kosten dieser vorliegenden Änderung / Cost of this change request	EURO
4.4 Voraussichtliche Gesamtsumme der Änderungen / Expected total cost of changes	EURO

5. Unterlagen / Documentation
- 5.1 zur Änderungsanforderung auf Basis geschätzter Kosten / supporting the Estimated Request:  
 Beschreibung/Begründung des Nachtrags durch das Bauamt (incl. Leistungsbeschreibung, Mengenermittlung, Einheitspreis, Gesamtpreis, Bewertung der Kosten) - siehe Anlage. / Description/reason for change by the Bauamt (including specification of works, quantity calculation, unit price, total price, cost evaluation) - see attachments.  
 Voraussichtliche Vorlage der geprüften und mit dem Auftragnehmer abgestimmten Änderung bis zum / Expected submission date of Negotiated Request Datum / Date
- 5.2 zur geprüften und mit dem Auftragnehmer abgestimmten Änderung / supporting the Negotiated Request:  
 Vollständiges Nachtragsangebot (Angebotsschreiben des Unternehmers, Nachtragsleistungsbeschreibung, begründende Unterlagen) / Complete change proposal (Written proposal of contractor, specification of works, explanatory documents)  
 Fachtechnische Stellungnahme (FTS) des Bauamtes (inkl. Bewertung des Unternehmerangebotes) / Technical Evaluation of Bauamt (including cost review of contractor's proposal)  
 Sonstige Unterlagen (z.B. Besprechungsprotokolle) / Other documentation (e.g. Minutes of meetings)
6. Einsparungsmöglichkeiten / Possibilities for Savings:  
 siehe Anlage Nr. / See Attachment No.:
7. Sonstiges / Miscellaneous
- 7.1 Auswirkungen auf den Bauablauf / Impacts on construction progress
- Keine weiteren erwarteten Auswirkungen, wenn dieser Änderung zugestimmt wird bis zum / No additional expected impacts if this change request is approved no later than Datum / Date
- Weitere erwarteten Auswirkungen, wenn nicht zugestimmt wird bis zum / Additional expected impacts if not approved until Datum / Date
- Verzögerung des Bauablaufes um (aber ohne erwartete Änderung des Fertigstellungstermins) - vgl. untenstehende Erläuterung\* / Delay in construction schedule (however with no expected change of final completion date) - see explanation below\* Werktage / working days
- Erwartete Änderung des Fertigstellungstermins - vgl. untenstehende Erläuterung\* / Expected change in final completion date - see explanation below\* Datum / Date
- Zusätzliche Mehrkosten entstehen - vgl. untenstehende Erläuterung\* / Incurrerend cost increases - see explanation below\* EURO  
 \*Erläuterung (in der Erläuterung werden die Auswirkungen einer Verzögerung zur Zustimmung dargestellt) / Explanation (the potential impacts of a delay in the approval of the change request are to be explained):
- 7.2 Sonstiges / Others:
8. Bemerkungen / Remarks:
9. Um Ihre Zustimmung wird gebeten / Your approval is requested.

Name / Name	Dienstbezeichnung / Title	Unterschrift / Signature	Datum / Date
-------------	---------------------------	--------------------------	--------------

**Part II / Teil II**  
 Change Order / Änderungsauftrag

US - Contract Modification No. / US - Vertrags-Änderungs-Nr.:	US - Change Order No. / US - Nachtrags-Nr.:
------------------------------------------------------------------	------------------------------------------------

10.  The above described change(s) is (are) noted and authority to proceed with is granted. Revised contract amounts are available (Article 12.3 up to 12.5 ABG 1975). The amount in Part I.4.4 shall not be exceeded without approval of the US Contracting Officer. / Die vorstehend beschriebene(n) Änderung(en) ist (sind) vermerkt und dürfen durchgeführt werden. Der Betrag für die geänderte Auftragssumme steht zur Verfügung (Artikel 12.3 bis 12.5 ABG 1975). Die in Teil I.4.4 genehmigte Summe darf ohne Zustimmung des Beschaffungsbeamten nicht überschritten werden.
- Authority to proceed with the request for change is not granted for the following reasons / Aus folgenden Gründen darf die Änderung nicht durchgeführt werden:
- Einschlägige begründende Unterlagen werden zur Einsicht erbeten – siehe Bemerkungen / Access to relevant documentation is requested – see remarks

Current Electronic Versions can be downloaded at [www.abg-plus.de/abg2/ebuecher/abg\\_us/downloadber.htm](http://www.abg-plus.de/abg2/ebuecher/abg_us/downloadber.htm)

11. Remarks / Bemerkungen:

12. Except as provided herein, all terms and conditions of the basic order (ABG 3) shall remain in full force and effect /  
Mit Ausnahme der hier aufgeführten Änderungen bleiben alle Bedingungen des Hauptauftrages (ABG 3) voll wirksam.

Issued by / Erteilt durch:

For the United States of America / Für die Vereinigten Staaten von Amerika:

Name / Name	Title / Dienstbezeichnung	Signature / Unterschrift	Date / Datum
-------------	---------------------------	--------------------------	--------------

Reference / Bezug:

**Part III / Teil III** (To be completed by the US Forces / Wird von den US-Streitkräften ausgefüllt)

Financial Statement / Kostenaufstellung\*:

- |   |                                                                                                                                                                            |   |      |
|---|----------------------------------------------------------------------------------------------------------------------------------------------------------------------------|---|------|
| a | Basic order and estimated value of changes previously approved and ordered / Hauptauftrag und geschätzte Kosten der bisher genehmigten und in Auftrag gegebenen Änderungen |   | EURO |
| b | Estimated value of this order / geschätzte Kosten dieses Auftrages                                                                                                         |   | EURO |
| c | Estimated total contract amount (a and b) / geschätzte Gesamtsumme (a und b)                                                                                               |   | EURO |
| d | Fee / Entschädigung                                                                                                                                                        | % | EURO |
| e | Total amount obligated to date (c and d) / zur Zeit festgelegte Gesamtsumme (c und d)                                                                                      |   | EURO |

\*All amounts net (excl.: VAT) / Alle Beträge netto (ohne Mehrwertsteuer)

Forces Internal Accounting Data / Für interne Buchungszwecke der Streitkräfte:



From / Address of the US Forces Agency / Adresse To / Appropriate German Authority / zuständige 3 copies / fach  
 Abs.: der Behörde der US-Streitkräfte An: deutsche Behörde

**US Forces Change Request (Re Article 4.2.2) /  
 Änderungsanforderung (zu Artikel 4.2.2)**

**ABG 1975/ABG 5A**

- Request for quote / Angebotsanforderung  
 Request for work / Leistungsanforderung

No. / Nr.

Reference / Az.:

US - Project Nr. /  
 US - Projekt No.:

Location / Ort:

Installation/Property /  
 Liegenschaft:

ABG 3 - Vertrags-Nr. /  
 ABG 3 - Contract No.:

Title / Bezeichnung:

lfd. ABG 4 - Nr. /  
 Übersetzung ABG 4 No.:

Type of Construction /  
 Art der Baumaßnahme:

Estimated Cost of this Change Request / Geschätzte Kosten dieser Änderungsanforderung: Euro

Forces Internal Accounting Data / Für interne Buchungszwecke der Streitkräfte:

1. The following change(s) to the above mentioned construction project is (are) requested: /  
 Es wird gebeten, bei o. a. Baumaßnahme folgende Änderung(en) vorzunehmen:
  - 1.1  Description of Change: / Beschreibung der Änderung: see attachment / siehe Anlage
  - 1.2  Reason for Change: / Begründung der Änderung: see attachment / siehe Anlage
2.  Authority to proceed with the above described change is granted. /  
 Die vorstehend beschriebene Änderung darf durchgeführt werden.  
 Funds in the amount are available of: / Mittel stehen zur Verfügung in Höhe von: Euro  
 and shall not be exceeded without approval of the US Contracting Officer. /  
 und dürfen ohne Genehmigung des US-Beschaffungsbeamten nicht überschritten werden.
3. Request submission of ABG 5 within 60 working days if possible based on: /  
 Anforderung des Formblattes ABG 5 möglichst innerhalb 60 Werktagen auf folgender Grundlage:
  - 3.1  Estimated costs / geschätzte Kosten
  - 3.2  Proposal negotiated between Bauamt and contractor / Geprüfte und abgestimmte Änderung
4. Please advise the US Forces if a new tender action (ABG 4) is required. /  
 Bitte informieren Sie die US-Streitkräfte, falls ein neues Ausschreibungsverfahren (ABG 4) erforderlich ist.
5.  Remarks / Bemerkungen:
6. Except as provided herein, all terms and conditions of the basic order (ABG 3) shall remain in full force and effect. / Mit  
 Ausnahme der hierin aufgeführten Änderungen bleiben alle Bedingungen des Auftrages (ABG 3) voll wirksam.

Issued by / Erteilt durch:  
 For the United States of America / Für die Vereinigten Staaten von Amerika:

Name / Name

Title / Dienstbezeichnung

Signature / Unterschrift

Date / Datum

From / (Address of the US Forces Authority) / To / (zuständige deutsche Behörde) / 3 copies / fach  
 Abs.: (Anschrift der Behörde der US-Streitkräfte) An: (Appropriate German Authority)

Abs. / (zuständige deutsche Behörde) / An / (Address of the US Forces Authority) / 1 fach / copy  
 from: (Appropriate German Authority) To: (Anschrift der Behörde der US-Streitkräfte)

**Order Document for Construction Works under Term Contract  
 (Article 1.8 ABG 1975) (use applicable VHB Form) /  
 Einzelanforderung für Zeitvertragsarbeiten (Artikel 1.8 ABG 1975)  
 (geltendes VHB - Formblatt ist zu verwenden)**

**ABG 1975/ABG 6**

Reference / Az.:

US - Project No. /  
 US - Projekt-Nr.:

Location / Ort:

Installation/Property /  
 Liegenschaft:

ABG 3 - Contract No. /  
 ABG 3 - Vertrags- Nr.:

Trade / Fachlos:

VHB - individual  
 construction order no. /  
 Formblatt VHB -  
 Einzelauftrags-Nr.:

Estimated Cost / EURO  
 Geschätzte Kosten:

Forces Internal Accounting Data / Für interne Buchungszwecke der Streitkräfte:

**Part I / Teil I**

Please instruct the firm / Bitte beauftragen Sie die Firma

to carry out the construction works described on the attached VHB Form in accordance with  
 the term contract dated /  
 die auf beigefügtem VHB - Formblatt beschriebenen Arbeiten auszuführen aufgrund des  
 Zeitvertrages vom

in the timeframe from / in der Zeit vom: to / bis zum

Funds in the amount of / Ausgabemittel stehen in Höhe von EURO  
 are available for FY / zur Verfügung für die Haushaltsjahre:

Name / Name	Title / Dienstbezeichnung	Signature / Unterschrift	Date / Datum
-------------	---------------------------	--------------------------	--------------

**Teil II / Part II**

Abs. / From: Zuständige deutsche Behörde / Competent German Authority

O.a. Anforderung wird bestätigt / The a/m request ist confirmed

Abdruck des Einzelauftrages vom / ist beigefügt: / fach /  
 Copies of individual construction order dated: are attached in copies

Name / Name	Dienstbezeichnung / Title	Unterschrift / Signature	Datum / Date
-------------	---------------------------	--------------------------	--------------

Abs. / From: Bauamt

An / To: Behörde der US-Streitkräfte / US Forces Agency 2 fach / copies  
 Fachaufsicht führende Ebene (FfE) 1 fach / copy  
 Bundesanstalt für Immobilienaufgaben 1 fach / copy

**Verhandlungsniederschrift - Übergabe von baulichen Anlagen durch die deutsche Baubehörde an die US-Streitkräfte (Artikel 14 ABG 1975) / Joint Minutes - Turnover of Construction Work by the German Building Authority to the US Forces (Article 14 ABG 1975)**

**ABG 1975/ABG 7**

Gesamtübergabe / Complete Turnover  Teilübergabe / Partial Turnover

Az. / Reference:

US - Projekt-Nr. /  
US - Project No.:

Ort / Location:

Liegenschaft /  
Installation/Property:

ABG - 3 Vertrags-Nr./  
ABG - 3 Contract No.:

Bezeichnung / Title:

Art der Baumaßnahme /  
Type of construction:

1. Die Übergabe folgender baulicher Anlagen /  
The turnover of the following construction work (name of project)

in at (location) war für den was set for (date) angesetzt um at nicht Entsprechend (time).

2. Die Übergabe erfolgte durch /  
The turnover to the US Forces was carried out by

unter Beteiligung der / (Deutsche Baubehörde / German Building Authorities)  
with the involvement of  
an die US-Streitkräfte / to the US Forces. (Bundesanstalt für Immobilienaufgaben / Federal Institute of Real Estate)

Teilnehmer siehe beigefügte Liste / List of those present see attached

3. Nach gemeinsamer Besichtigung der baulichen Anlagen wurde von den US-Streitkräften festgestellt, dass die baulichen Anlagen den von den Streitkräften genehmigten Bauunterlagen einschließlich der geltenden Bauverträge / entsprechen. /  
Upon joint inspection of the construction work, it was concluded by the US Forces that the construction work is / is not in accordance with the approved design documents including the applicable construction contracts nicht entsprechen. /  
is not in accordance with.

Die Übergabe / The construction work  hat stattgefunden. / was turned over.  konnte nicht stattfinden, da die baulichen Anlagen wegen Mängeln nach Art. 14.2 ABG 1975 nicht benutzbar sind. / could not be turned over because of deficiencies that render it unsuitable for use (Re Article 14.2 ABG 1975).

4. 4.1 Folgende Mängel wurden durch die deutsche Baubehörde festgestellt: / keine / siehe beigefügte Liste /  
The following deficiencies were noted by the German Building Authority: none see attached list

4.2 Folgende Mängel wurden durch die US-Streitkräfte festgestellt: / keine / siehe beigefügte Liste /  
The following deficiencies were noted by the US Forces: none see attached list

5. 5.1 Nach Abstimmung sind folgende Abhilfemaßnahmen/ Mängelbeseitigungen gemäß VOB vorgesehen: / keine / siehe beigefügte Liste /  
In accordance with the VOB the following coordinated remedial action is proposed: none see attached list

- 5.2 Die US-Streitkräfte sind mit den vorgesehenen einverstanden. / nicht einverstanden und  
 Abhilfemaßnahmen/Mängelbeseitigungen / agree.  schlagen Nachfolgendes vor: /  
 With the proposed remedial action the US Forces  do not agree and recommend  
 the following:

5.3 Bemerkungen / Remarks:

6. Anlagen (zu Art. 7.1.8 und 7.1.9 ABG 1975) / Enclosures (re Article 7.1.8 and 7.1.9 ABG 1975)

- 6.1  digitale Baubestandszeichnungen / digitized as-built drawings  
 (Eine digitale Fassung sendet das Bauamt an die Bundesanstalt für Immobilienaufgaben /  
 One digitized copy will be provided by the Bauamt to the Federal Institute of Real Estate)
- 6.2  eine Papieraufbereitung der Baubestandszeichnungen / one printed version of as-built drawings
- 6.3  Für die Inbetriebnahme technischer Einrichtungen erforderlicher Unterlagen gemäß RBBau Abschnitt H (vgl.  
 Ausführungen zu Art. 7.7.2) / Documents required for the operation of technical installations according to RBBau  
 Section H (Re Article 7.7.2 of the Implementing Instructions)
- 6.4  Geräteverzeichnis mit Ersatzteillisten / list of equipment and/or machinery with parts lists
- 6.5  sonstige Unterlagen über geleistete Arbeiten / other publications applicable to the completed construction  
 works (e.g. in accordance with terms of contract order).
- 6.6  Übersicht der Gewährleistungsfristen und Ablauftermine /  
 statement of the periods and expiration dates of the warranties
- 6.7  sämtliche vorgeschriebenen Abnahmebescheinigungen / all acceptance certificates required
- 6.8  sämtliche Schlüssel / all key systems
- 6.9  Weitere im folgenden aufgeführte Dokumente entsprechend der RBBau /  
 Other relevant documentation (e.g. that referred to in RBBau Section H) as listed below:  
 (1)  
 (2)  
 (3)
- 6.10  Betriebs- und Instandhaltungsbücher sowie Anweisungen zur praktisch technischen  
 Ausbildung wurden zur Verfügung gestellt. / Operation and maintenance manuals and  
 hands-on training/technical instruction were provided.
- 6.11  Betriebs- und Instandhaltungsbücher sowie Anweisungen zur praktisch technischen Datum / Date  
 Aus-bildung werden gemäß Vereinbarung mit den US-Streitkräften zur Verfügung  
 gestellt am: / Operation and maintenance manuals and hands-on training/technical  
 instruction will be provided as agreed with US Forces on Date:

Die Anlagen zu 6 / Paragraph 6 attachments:

Die Ausfertigungen der digitalen Fassungen zu 6.1, 6.6, 6.7 und 6.9 werden gemäß UP ABG 1975 zu Art. 7.1.9 innerhalb  
 von 78 Werktagen nach Übergabe des fertig gestellten Bauwerks zur Verfügung gestellt. / The copies of the digital  
 versions of 6.1, 6.6, 6.7 and 6.9 above will be made available in accordance with Article 7.1.9 UP ABG 1975 (Protocol of  
 Signature, ABG 1975) within 78 workdays after turnover of the completed building.

7.  Stand der Abrechnung (z. B. eventuelle Kosten aus Streitigkeiten, geschätzte Mengenminderungen/  
 etc.) - vgl. Anlage / Status of accounts (e.g. potential costs arising from known disputes, estimated quantity  
 overruns/underruns, etc.) - see attached
8.  Bemerkungen / Remarks:

9. Die Sitzung wurde geschlossen um / The meeting was closed at: Uhr / Time

Für die deutsche Baubehörde / For the German Building Authority

Dienststelle / Office	Name / Name	Dienstbezeichnung / Title	Unterschrift / Signature	Datum / Date
-----------------------	-------------	---------------------------	--------------------------	--------------

Für die Bundesanstalt für Immobilienaufgaben / For the Federal Institute of Real Estate

Dienststelle / Office	Name / Name	Dienstbezeichnung / Title	Unterschrift / Signature	Datum / Date
-----------------------	-------------	---------------------------	--------------------------	--------------

Für die US-Streitkräfte / For the agency of the US Forces

Dienststelle / Office	Name / Name	Dienstbezeichnung / Title	Unterschrift / Signature	Datum / Date
-----------------------	-------------	---------------------------	--------------------------	--------------

(Raum für zusätzliche Namen, falls erforderlich / Space for additional names if required)

Abs. / From  Fachaufsicht führende Ebene  
 Bauamt

An / To: Behörde der US-Streitkräfte / US Forces Agency 2 fach / copies  
 Fachaufsicht führende Ebene 1 fach / copy  
 Bauamt 1 fach / copy  
 Bundesanstalt für Immobilienaufgaben 1 fach / copy

**Niederschrift über die gemeinsame Schlussbesichtigung der baulichen Anlagen die von den US-Streitkräften im Truppenbauverfahren durchgeführt wurden (Artikel 37.1 ABG 1975) / Record of the joint final inspection of construction work executed by the US-Forces using the Direct Procedure (Article 37.1 ABG 1975)**

**ABG 1975/ABG 7B**

Az. / Reference:  Ort / Location:  Liegenschaft / Installation/Property:  Bezeichnung / Title:  Art der Baumaßnahme / Type of construction:	US – Projekt-Nr. / US – Project No.:  ABG 2 - Vertrags-Nr. / ABG 2 – Contract No.:
---------------------------------------------------------------------------------------------------------------------------------------------------------------------	------------------------------------------------------------------------------------------

Für interne Buchungszwecke der Streitkräfte / Forces Internal Accounting Data:

1. Die Schlussbesichtigung der baulichen Anlagen war für den Um  
 The final inspection of the construction work was set for (date) at Uhr angesetzt. / (time)
  
2. Die Teilnehmer an der Schlussbesichtigung, welche die deutsche Baubehörde, die Bundesanstalt für Immobilienaufgaben und die US-Streitkräfte vertraten, waren wie aufgeführt. / Taking part in the final inspection as representatives of the German Building Authority, the Federal Institute for Real Property and the US Forces, were the following.

Name / Name	Dienstbezeichnung / Title

3. Nach gemeinsamer Besichtigung der baulichen Anlagen wurde durch die deutschen Behörden festgestellt, dass die baulichen Anlagen der Planung und den deutschen Vorschriften (Art. 34 ABG 1975) / Upon joint inspection of the construction work, it was concluded by the German authorities that the construction work with the plans and the German regulations (Article 34 ABG 1975)  entsprechen. / is in accordance.  nicht entsprechen. / is not in accordance.
4. Folgende Mängelbeseitigungen aus öffentlich-rechtlicher Sicht werden von der deutschen Baubehörde für erforderlich gehalten (Art. 37.2 ABG 1975): / The following deficiencies are, for reasons of public law, considered necessary by the German Building Authority to be remedied (Article 37.2 ABG 1975):  keine / none  werden innerhalb von 6 Werktagen schriftlich mitgeteilt. / will be given in writing within 6 workdays.
5.  Digitalisierte Baubestandszeichnungen in 2-facher Ausfertigung werden erbeten bis zum: / Datum / Date  
two digital versions of the as-built drawings are requested no later than:
- Die zweite Ausfertigung wird der zuständigen Liegenschaftsverwaltung des Bundes übergeben. / The second copy will be turned over to the responsible Federal Institute for Real Estate.  
Empfänger ist / The recipient is:

6. Bemerkungen / Remarks:

---

---

---

---

---

---

---

---

---

---

---

---

---

---

---

---

---

---

---

---

7. Die Schlussbesichtigung war beendet um \_\_\_\_\_ Uhr. /  
The final inspection finished at \_\_\_\_\_ time.

Für die deutsche Baubehörde / For the German Building Authority:

Dienststelle / Office	Name / Name	Dienstbezeichnung / Title	Unterschrift / Signature	Datum / Date
-----------------------	-------------	---------------------------	--------------------------	--------------

Für die Bundesanstalt für Immobilienaufgaben / For the Federal Institute for Real Estate:

Dienststelle / Office	Name / Name	Dienstbezeichnung / Title	Unterschrift / Signature	Datum / Date
-----------------------	-------------	---------------------------	--------------------------	--------------

Für die US-Streitkräfte / For the US Forces:

Dienststelle / Office	Name / Name	Dienstbezeichnung / Title	Unterschrift / Signature	Datum / Date
-----------------------	-------------	---------------------------	--------------------------	--------------

(Raum für zusätzliche Namen, falls erforderlich / Space for additional names if required)

Abs. / (zuständige deutsche Behörde) /  
From: (Appropriate German Authority)

An / (Anschrift der Behörde der US-Streitkräfte) / 6 fach / copies  
To: (Address of the US Forces Authority)

**Baukosten (Artikel 25 ABG 1975) /  
Construction Costs (Article 25 ABG 1975)**

**ABG 1975/ABG 8**

Teilrechnung / Partial Invoice  Schlussrechnung / Final Invoice

HKR-Kontroll-Nr. / HKR-Control-No.:

- 8

Die HKR-Kontroll-Nr. muss auf allen Schriftstücken einschließlich Zahlungen (Schecks), die sich auf diese Rechnung beziehen, angegeben werden. / The HKR-Control-number must be shown on all documents incl. payment documents (checks) related to this invoice.

Kassenzeichen / Transaction Number

Zahlungsdokument/Scheck an / Payment document/check to  
spätestens bis zum / no later than

Az. / Reference:

Ort / Location:

Liegenschaft /  
Installation/Property:

Bezeichnung / Title:

Art der Baumaßnahme /  
Type of Construction:

ABG 3 - Vertrags-Nr. /  
ABG 3 - Contract No.:

US - Projekt-Nr. /  
US - Project No.:

einschl. US - Vertrags-  
Änderungs-Nr. / incl. US -  
Contract Modification No.:

über / amount  
EURO (netto / net)

Teilrechnung Nr. / Partial invoice No. über / amount EURO (netto / net)  
 Schlussrechnung Nr. / Final invoice No. über / amount EURO (netto / net)

		Betrag / Amount EURO (netto/net)
1.1	Wert der bis heute geleisteten Arbeiten / Value of work performed to date % aus / of ergibt:	
1.2	Wert der bis heute erfolgten Lieferungen / Value of supplies furnished to date % aus / of ergibt:	+
2.	Gesamtbetrag / Grand Total	
3.	Abzüglich der bisher eingereichten Rechnungen / Less invoices submitted to date Nr. / No. bis / up to	-
4.	<b>Auszuzahlender Betrag / Amount to be paid</b>	

5. Auftragnehmer Rechnung/en mit Nr. / Construction Contractor Invoice/s No.:  
mit Rechnungseingangsdatum ist/sind beigelegt. / with date of receipt of the  
invoice is/are attached.  
Datum vom / Dated:

Ich bestätige, dass diese Rechnung sachlich und rechnerisch richtig ist, dass keine Zahlung hierfür empfangen worden ist und dass die Preise keine Steuern und Zölle enthalten, von denen die Regierung der Vereinigten Staaten befreit ist, wie in Art. 6 ABG 1975 dargelegt. /

I certify, that the above invoice is correct and just, that payment therefor has not been received, and that the prices therein are exclusive of all taxes or duties which are not applicable to the United States Government as set forth in article 6 ABG 1975.

Die Umsatzsteuer-(Mehrwertsteuer-) Vergünstigung beträgt /  
The amount of the turnover tax (value added tax) benefit is %

der Nettobaukosten /  
of the net total cost of construction = EURO

- Im Auftrag des Bundesministerium für Verkehr, Bau und Stadtentwicklung  
 Im Auftrag des Bundesministerium der Verteidigung  
 Fachaufsicht führende Ebene  
 Bauamt

I certify that the services covered by this invoice have been rendered in accordance with the terms of the above referenced contract order and payment therefor has been initiated. /

Ich bestätige, dass die in dieser Rechnung enthaltenen Leistungen in Übereinstimmung mit den Bedingungen des oben genannten Vertrags/ Auftrags erbracht sind und die Überweisung des Rechnungsbetrages veranlasst wurde.

For the United States of America / Für die Vereinigten Staaten von Amerika

Datum / Date

Unterschrift und Dienstbezeichnung

Date / Datum

Signature and Title

Abs. / (zuständige deutsche Behörde) /  
From: (Appropriate German Authority)

To / (Address of the US Forces Authority) / 6 fach / copies  
An: (Anschrift der Behörde der US-Streitkräfte)

**Verwaltungsentschädigung (Artikel 26 ABG 1975) /  
Administrative Fee (Article 26 ABG 1975)**

**ABG 1975/ABG 9**

Teilrechnung / Partial Invoice

Schlussrechnung / Final Invoice

HKR-Kontroll-Nr. / HKR-Control-No.:

- 9

Die HKR-Kontroll-Nr. muss auf allen Schriftstücken einschließlich Zahlungen (Schecks), die sich auf diese Rechnung beziehen, angegeben werden. / The HKR-Control-number must be shown on all documents incl. payment documents (checks) related to this invoice.

Kassenzeichen / Transaction Number

Zahlungsdokument/Scheck an / Payment document/check to  
spätestens bis zum / no later than

Az. / Reference:

ABG 3 - Vertrags-Nr. /  
ABG 3 - Contract No.:

US - Projekt Nr. /  
US - Project No.:

Ort / Location:

Liegenschaft /  
Installation/Property:

einschl. US - Vertrags-  
Änderungs-Nr. / incl. US -  
Contract Modification No.:

über / amount  
EURO (netto / net)

Bezeichnung / Title:

Art der Baumaßnahme /  
Type of Construction:

Teilrechnung Nr. / Partial invoice No.

über / amount

EURO (netto / net)

Schlussrechnung Nr. / Final invoice No.

über / amount

EURO (netto / net)

		Betrag / Amount EURO (netto/net)
1	<b>Große Neu-, Um- und Erweiterungsbauten (Art. 1.4.2 ABG 1975) / Major new construction, alterations and extension (article 1.4.2 ABG 1975)</b>	
	Baukosten nach Art. 21.3 ABG 1975 / Construction costs pursuant to article 21.3 ABG 1975	EURO
	Prozentsatz nach Art. 23.1.2 ABG 1975/UP ABG 1975 zu Art. 23 / Percentage pursuant to article 23.1.2 ABG 1975/PS re article 23	5,6 %
	Leistungsstand nach den Ausführungen zu Art. 26.1 / Phase of service pursuant to article 26.1 of these Implementing Instructions	%
	_____ EURO x 5,6 % x _____ %	
	Gemeinsam festgestellte Baukosten nach Artikel 24.1.1 ABG 1975 / Jointly determined construction costs pursuant to article 24.1.1 ABG 1975	EURO
	Entschädigung nach Art. 24.1.1 bis 24.2 ABG 1975/Ausführungen zu Art. 24 (s. Anlage) / Fee pursuant to article 24.1.1 to 24.2 ABG 1975/Art. 24 of these Implementing Instructions (see annex)	



2	<b>Instandsetzung und Instandhaltung, kleine und kleinere Neu-, Um- und Erweiterungsbauten (Art. 1.3, 1.4.1, 1.4.3 ABG 1975) /</b> <b>Repair and Maintenance, minor and very minor new construction, alterations and extensions, (Article 1.3, 1.4.1, 1.4.3 ABG 1975)</b>	Betrag / Amount
	Baukosten nach Artikel 21.3 ABG 1975 / Construction costs pursuant to article 21.3 ABG 1975	EURO
	Prozentsatz nach Art. 23.1.1 ABG 1975/UP ABG 1975 zu Art. 23 / Percentage pursuant to article 23.1.1 ABG 1975/PS re article 23	7,5 %
	Leistungsstand nach den Ausführungen zu Art. 26.1 / Phase of service pursuant to article 26.1 of these Implementing Instructions	%
	_____ EURO x 7,5 % x _____ %	
	Gemeinsam festgestellte Baukosten nach Artikel 24.1.1 ABG 1975 / Jointly determined construction costs pursuant to article 24.1.1	EURO
	Entschädigung nach Art. 24.1.1 bis 24.2 ABG 1975/Ausführungen zu Art. 24 (s. Anlage) / Fee pursuant to article 24.1.1 to 24.2 ABG 1975/Art. 24 of these Implementing Instructions (see annex)	
3	Kostenerstattung für Gebühren/Sonderleistungen / Reimbursement for fees/additional services: <input type="checkbox"/> Planungsphase / Design Phase (D) <input type="checkbox"/> Bauphase / Construction Phase (C)	
	1. _____ EURO 2. _____ + _____ EURO 3. _____ + _____ EURO 4. _____ + _____ EURO	+
4	Gesamtbetrag / Grand Total	
5	Abzüglich der bisher eingereichten Rechnungen / Less invoices submitted to date Nr. / No. bis / up to	-
6	Auszuzahlender Betrag / Amount to be paid	

Ich bestätige, dass diese Rechnung sachlich und rechnerisch richtig ist, dass keine Zahlung hierfür empfangen worden ist und dass die Preise keine Steuern und Zölle enthalten, von denen die Regierung der Vereinigten Staaten von Amerika befreit ist, wie in Art. 6 ABG 1975 dargelegt. / I certify, that the above invoice is correct and just, that payment therefor has not been received, and that the prices therein are exclusive of all taxes or duties which are not applicable to the United States Government as set forth in article 6 ABG 1975.  Die Umsatzsteuer-(Mehrwertsteuer Vergünstigung beträgt / The amount of the turnover tax (value added tax) benefit is _____ %  der Nettobaukosten / of the net total cost of construction = _____ EURO  <input type="checkbox"/> Im Auftrag des Bundesministerium für Verkehr, Bau und Stadtentwicklung <input type="checkbox"/> Im Auftrag des Bundesministerium der Verteidigung <input type="checkbox"/> Fachaufsicht führende Ebene <input type="checkbox"/> Bauamt	I certify that the services covered by this invoice have been rendered in accordance with the terms of the above referenced contract order and payment therefor has been initiated. / Ich bestätige, dass die in dieser Rechnung enthaltenen Leistungen in Übereinstimmung mit den Bedingungen des oben genannten Vertrags/ Auftrags erbracht sind und die Überweisung des Rechnungsbetrages veranlasst wurde.  For the United States of America /Für die Vereinigten Staaten von Amerika:		
Datum / Date	Unterschrift und Dienstbezeichnung	Date / Datum	Signature and Title

*Current Electronic Versions can be downloaded at [www.abg-plus.de/abg2/ebuecher/abg\\_us/downloadber.htm](http://www.abg-plus.de/abg2/ebuecher/abg_us/downloadber.htm)*

**APPENDIX II**  
**ABG 1975 FLOWCHARTS**

## Ablaufschema zu ABG 1 / Flow Chart for ABG 1 (Art. 3 ABG 1975)

(Programmabstimmung / Program Coordination)

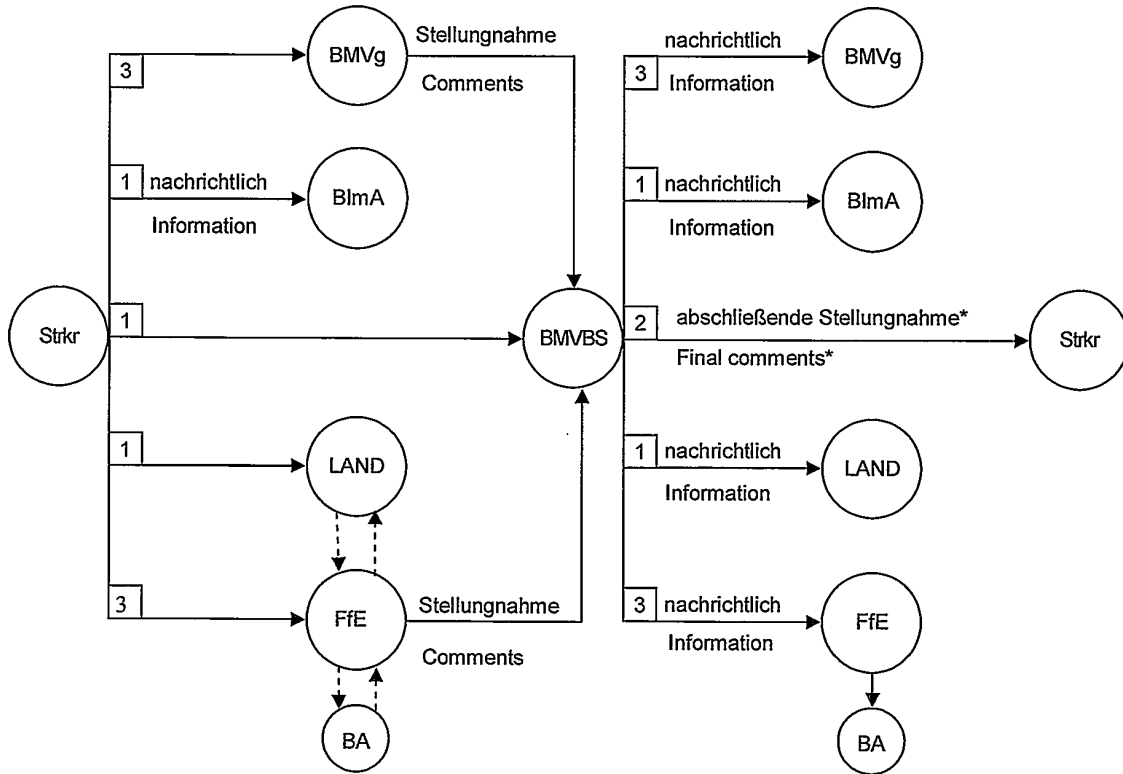

☐ - Anzahl der Fertigungen / Number of Copies

\* einschließlich Zuständigkeitszuordnung (BMVBS/BMVg) / including determination of the responsible Ministry (BMVBS/BMVg)

### Abkürzungen / Acronyms:

Strkr	Streitkräfte / Armed Forces
BMVBS	Bundesministerium für Verkehr, Bau und Stadtentwicklung / Federal Ministry of Transport, Building and Urban Affairs
BMVg	Bundesministerium der Verteidigung / Federal Ministry of Defense
Land	zuständiges Landesministerium / Responsible State Ministry
FfE	Fachaufsicht führende Ebene / Agency Responsible for Technical Oversight
BA	Bauamt / Building Authority
BlmA	Bundesanstalt für Immobilienaufgaben / Federal Institute for Real Estate

### Ablaufschema zu ABG 2 / Flow Chart for ABG 2 (Art. 27 ABG 1975)

(Benachrichtigung über Vorhaben im Truppenbau bei Instandsetzung und Instandhaltung ohne Wertgrenzen und Kleinere Neu-, Um- und Erweiterungsbauten bis 150.000 Euro\* / Letter of intent for direct procedure for repair and maintenance work regardless of costs and very minor construction, alterations and extensions up to and including EURO 150.000\*

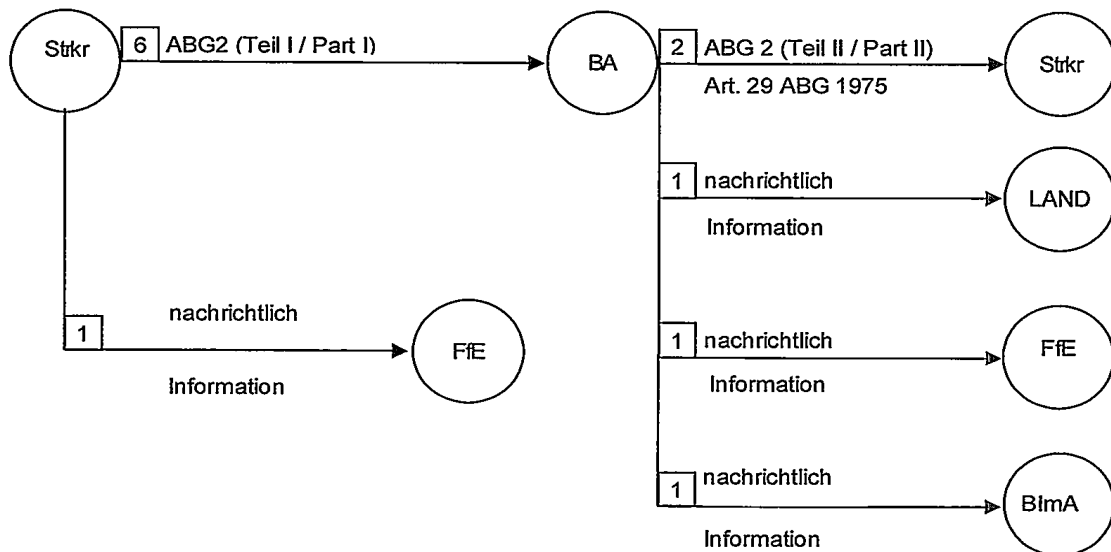

\*nur zutreffend in Fällen bei denen Genehmigungen erforderlich sind oder sein können oder Kenntnissgaben notwendig sind nach Art. 30.1 ABG 1975 / only applicable in cases where permissions may be required or notifications must be made according to Art 30.1 ABG 1975.

### Ablaufschema zu ABG 2 / Flow Chart for ABG 2 (Art. 27 ABG 1975)

(Benachrichtigung über Vorhaben im Truppenbau bei Neu-, Um- und Erweiterungsbauten über 150.000 bis 375.000 Euro / Letter of intent for direct procedure for new construction, alterations and extensions over 150.000 up to and including EURO 375.000)

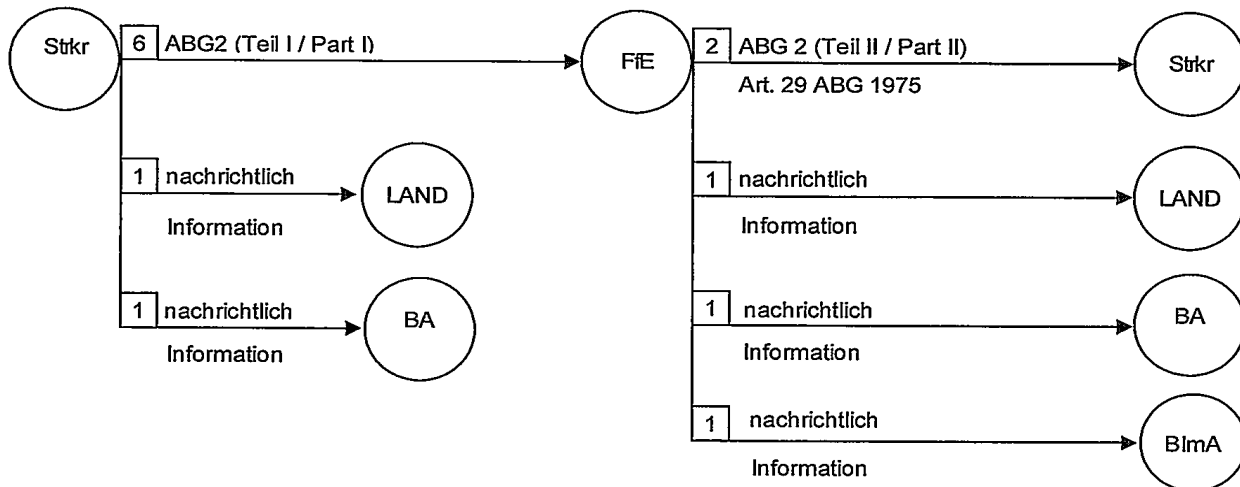

## Ablaufschema zu ABG 2 / Flow Chart for ABG 2 (Art. 27 ABG 1975)

(Benachrichtigung über Vorhaben im Truppenbau bei Neu-, Um- und Erweiterungsbauten über 375.000 Euro /

Letter of intent for direct procedure for new construction, alterations and extensions over EURO 375.000)

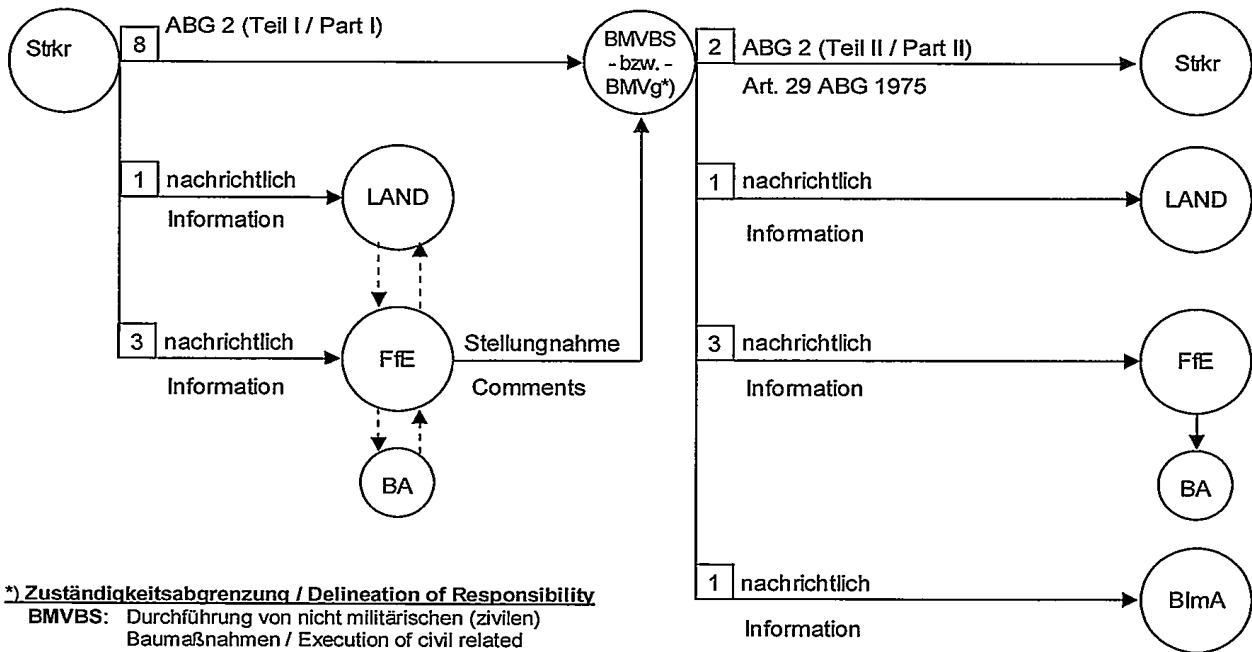

**\*) Zuständigkeitsabgrenzung / Delineation of Responsibility**

**BMVBS:** Durchführung von nicht militärischen (zivilen) Baumaßnahmen / Execution of civil related construction

**BMVg:** Durchführung von militärischen Baumaßnahmen / Execution of defence related construction

☐ - Anzahl der Fertigungen / Number of Copies

Abkürzungen / Acronyms:	
Strkr	Streitkräfte / Armed Forces
BMVBS	Bundesministerium für Verkehr, Bau und Stadtentwicklung / Federal Ministry of Transport, Building and Urban Affairs
BMVg	Bundesministerium der Verteidigung / Federal Ministry of Defense
Land	zuständiges Landesministerium / Responsible State Ministry
FfE	Fachaufsicht führende Ebene / Agency Responsible for Technical Oversight
BA	Bauamt / Building Authority
BlmA	Bundesanstalt für Immobilienaufgaben / Federal Institute for Real Estate

### Ablaufschema zu ABG 3 / Flow Chart for ABG 3 (Art.10 ABG 1975)

(Anforderung bei Kleineren Neu-, Um- und Erweiterungsbauten bis 150.000 Euro und Instandsetzung und Instandhaltung ohne Wertgrenze / Request for services for very minor construction, alterations and extensions up to and including Euro 150.000 and repair and maintenance work regardless of cost)

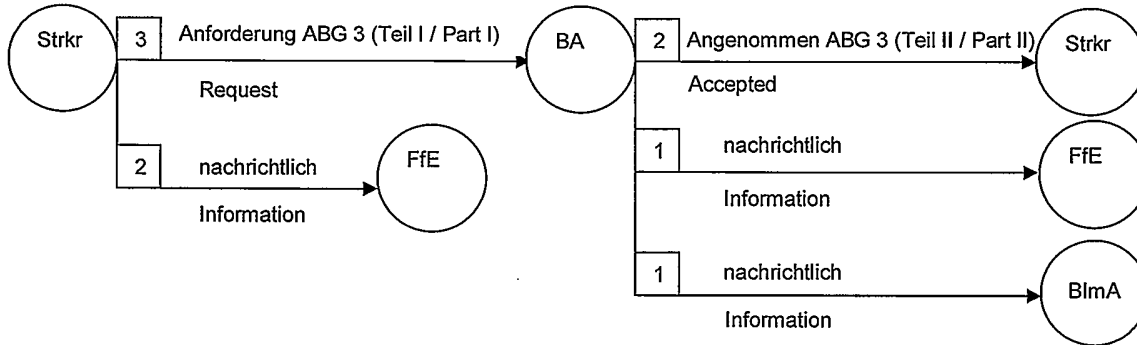

### Ablaufschema zu ABG 3 / Flow Chart for ABG 3 (Art.10 ABG 1975)

(Anforderung bei Neu-, Um- und Erweiterungsbauten über 150.000 bis 375.000 Euro / Request for for new construction, alterations and extensions over 150.000 up to and including 375.000 Euro)

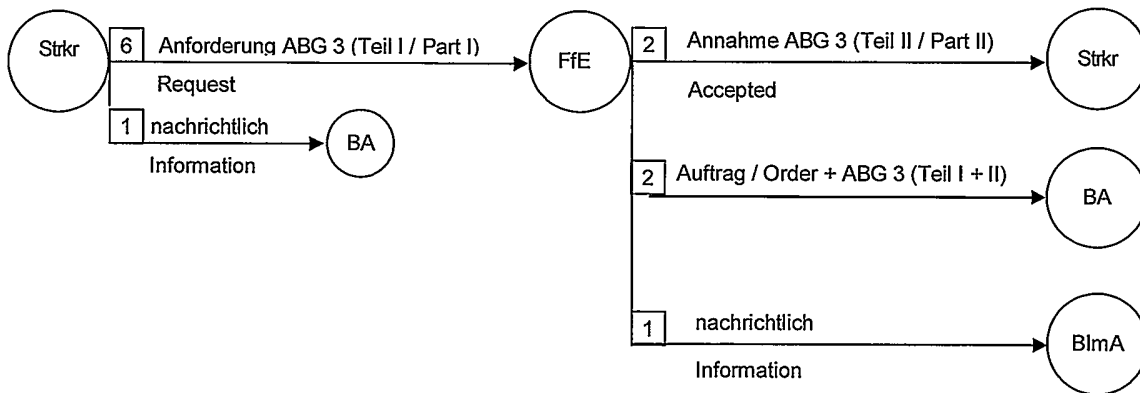

## Ablaufschema zu ABG 3 / Flow Chart for ABG 3 (Art. 10 ABG 1975)

(Anforderung bei Neu-, Um- und Erweiterungsbauten über 375.000 Euro /  
Request for new construction, alterations and extensions over Euro 375.000)

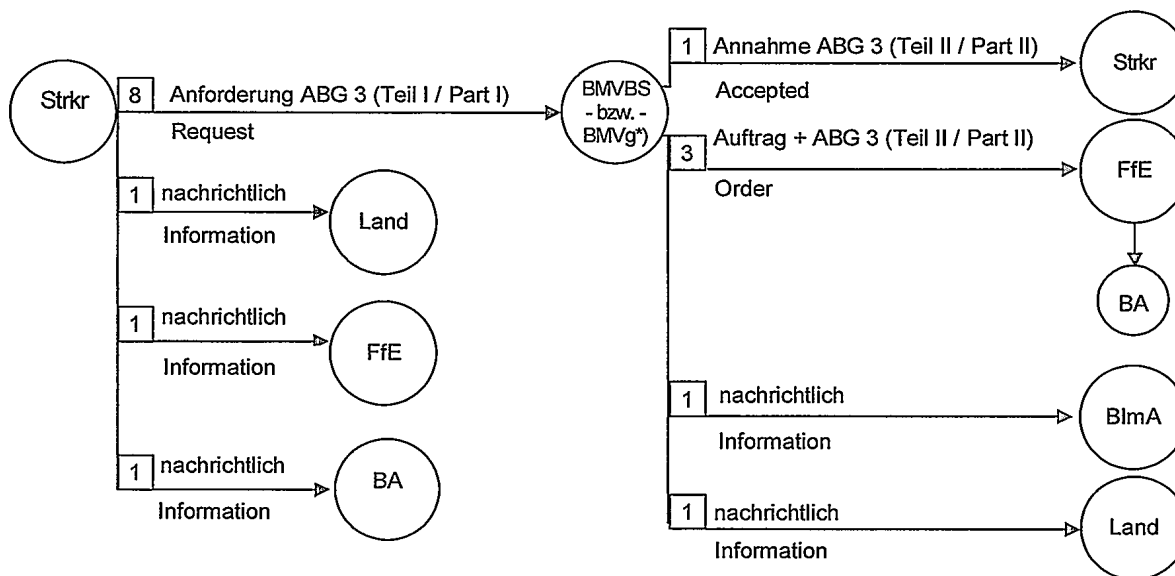

☐ - Anzahl der Fertigungen / Number of Copies

**\*) Zuständigkeitsabgrenzung / Delineation of Responsibility**

BMVBS: Durchführung von nicht militärischen (zivilen) Baumaßnahmen / Execution of civil related construction

BMVg: Durchführung von militärischen Baumaßnahmen / Execution of defense related construction

**Ergänzender Hinweis / additional note:**

Weitere in Art. 7 ABG 1975 beschriebene Leistungen (Modifikationen) für Baumaßnahmen über Euro 375.000 werden durch die FfE angenommen analog dem Verfahren bei Baumaßnahmen über 150.000 bis 375.000 Euro. /

Further services described in Art. 7 ABG 1975 (modifications) for construction measures over Euro 375.000 shall be accepted by the FfE analogous to the procedure for construction measures over Euro 150.000 up to and including Euro 375.000.

**Abkürzungen / Acronyms:**

Strkr	Streitkräfte / Armed Forces
BMVBS	Bundesministerium für Verkehr, Bau und Stadtentwicklung / Federal Ministry of Transport, Building and Urban Affairs
BMVg	Bundesministerium der Verteidigung / Federal Ministry of Defence
Land	zuständiges Landesministerium / Responsible State Ministry
FfE	Fachaufsicht führende Ebene / Agency Responsible for Technical Oversight
BA	Bauamt / Building Authority
BImA	Bundesanstalt für Immobilienaufgaben / Federal Institute for Real Estate

## Ablaufschema zu ABG 4 / Flow Chart for ABG 4 (Art. 10.1.5 ABG 1975)

(Angebotsannahme / Tender acceptance form)

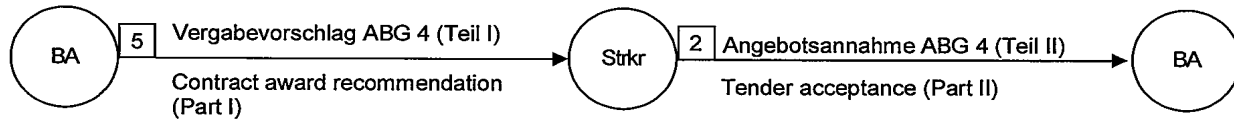

- Anzahl der Fertigungen / Number of Copies

### Abkürzungen / Acronyms:

Strkr	Streitkräfte / Armed Forces
BA	Bauamt / Building Authority
VHB	Vergabe- und Vertragshandbuch für Baumaßnahmen des Bundes / Contracting and Award Manual for Federal Construction Projects



### Ablaufschema zu ABG 5 / Flow Chart for ABG 5 (Art. 12 ABG 1975)

(Änderungsdokument / Change order document)

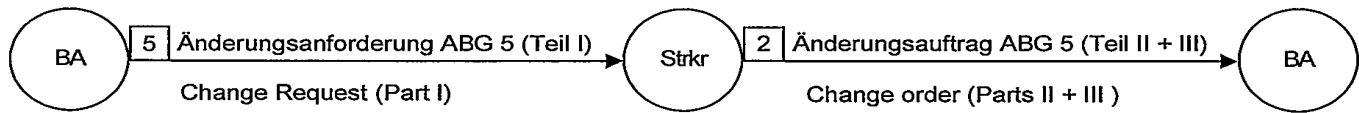

### Ablaufschema zu ABG 5A / Flow Chart for ABG 5A (Re Art. 4.2.2)

(Änderungsanforderung / Change Request)

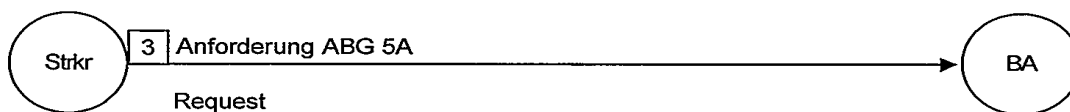

- Anzahl der Fertigungen / Number of Copies

#### Abkürzungen / Acronyms:

Strkr	Streitkräfte / Armed Forces
BA	Bauamt / Building Authority

### Ablaufschema zu ABG 6 / Flow Chart for ABG 6 (Art. 1.8 ABG 1975)

(Einzelanforderung für Zeitvertragsarbeiten bei Baumaßnahmen /  
Order document for construction works under term contract)

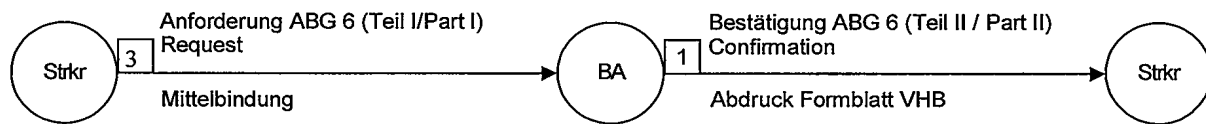

**Abkürzungen / Acronyms:**

Strkr	Streitkräfte / Armed Forces
BA	Bauamt / Building Authority
VHB	Vergabe- und Vertragshandbuch für Baumaßnahmen des Bundes / Contracting and Award Manual for Federal Construction Projects

### Ablaufschema zu ABG 7 / Flow Chart for ABG 7 (Art. 14 ABG 1975)

(Verhandlungsniederschrift - Übergabe von baulichen Anlagen durch die deutsche Baubehörde an die US-Streitkräfte /  
Joint Minutes - Turnover of construction work by the German Building Authority to the US Forces)

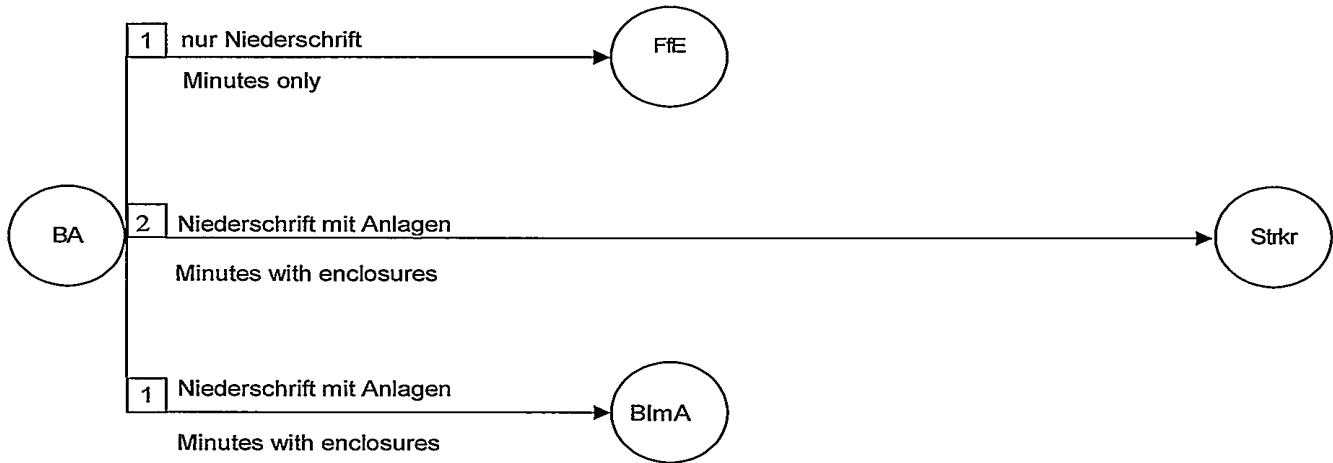

### Ablaufschema zu ABG 7B / Flow Chart for ABG 7B (Art. 37 ABG 1975)

(Niederschrift über die gemeinsame Schlussbesichtigung der baulichen Anlagen, die von den US-Streitkräften im  
Truppenbauverfahren durchgeführt wurden /  
Record of the joint final inspection of construction work executed by the US-Forces using the Direct Procedure)

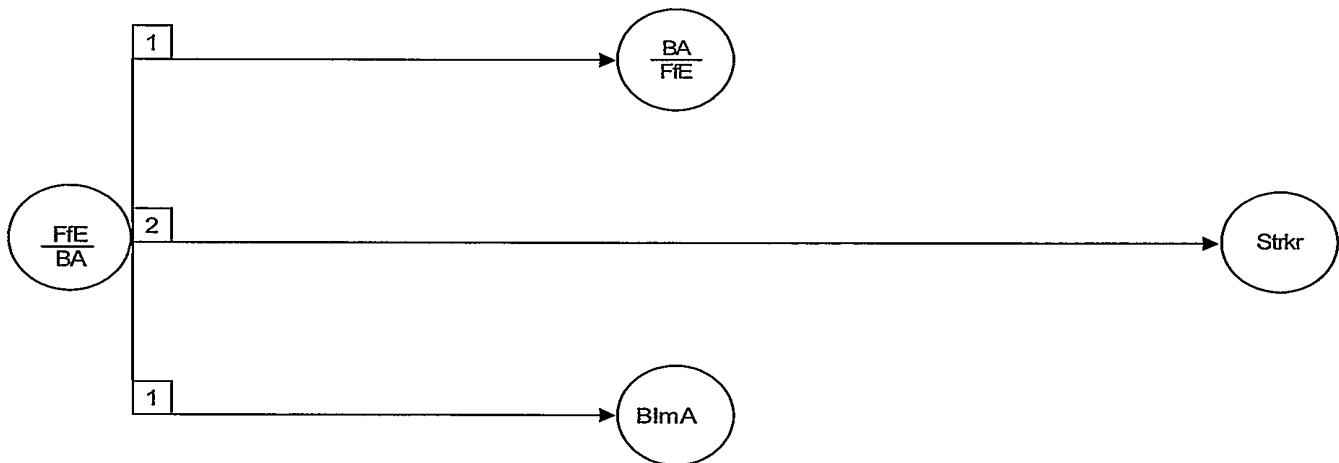

- Anzahl der Fertigungen / Number of Copies

#### Abkürzungen / Acronyms:

Strkr	Streitkräfte / Armed Forces
FfE	Fachaufsicht führende Ebene / Agency Responsible for Technical Oversight
BA	Bauamt / Building Authority
BlmA	Bundesanstalt für Immobilienaufgaben / Federal Institute for Real Estate

## Ablaufschema zu ABG 8 / Flow Chart for ABG 8 (Art. 25 ABG 1975)

(Baukosten / Construction Costs)

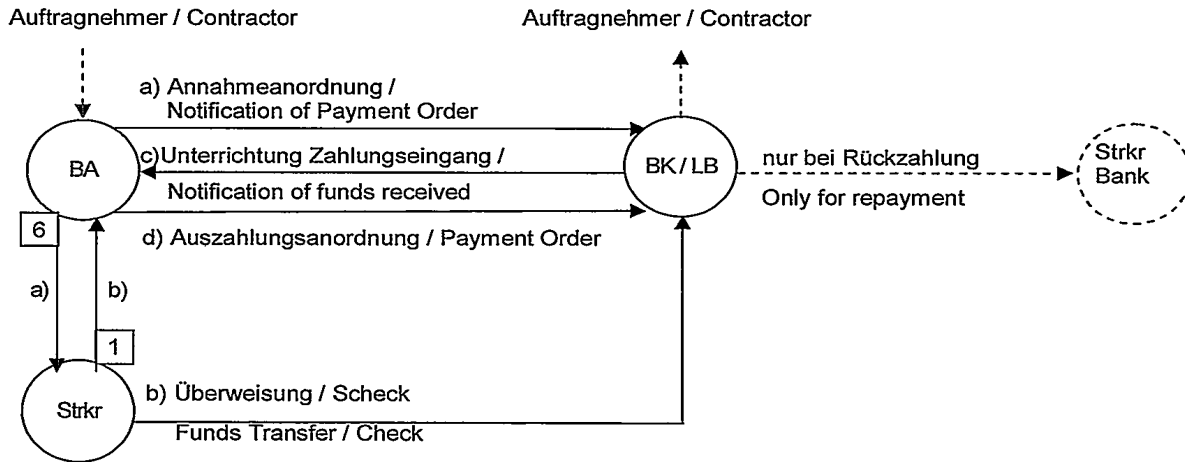

a) ABG 8 mit Anl. / ABG 8 with encl.  
b) ABG 8 bestätigt / ABG 8 certified

## Ablaufschema zu ABG 9 / Flow Chart for ABG 9 (Art. 26 ABG 1975)

(Verwaltungsentschädigung / Administrative Fee)

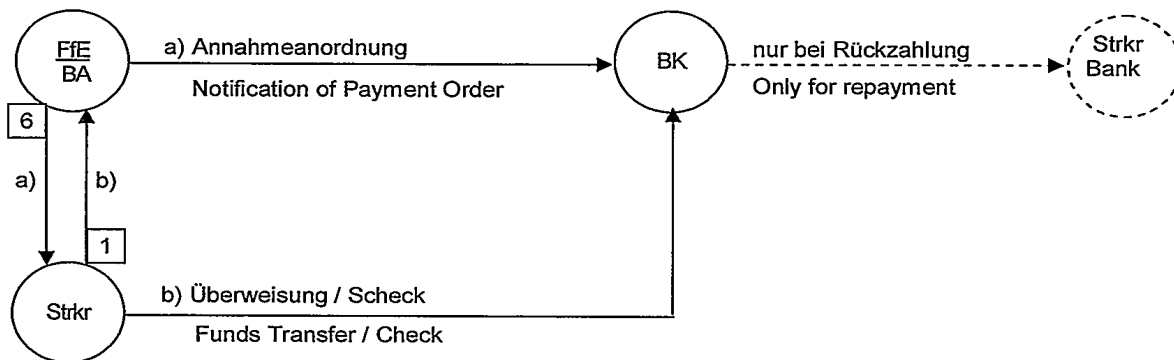

a) ABG 9 mit Anl. / ABG 9 with encl.  
b) ABG 9 bestätigt / ABG 9 certified

- Anzahl der Fertigungen / Number of Copies

### Abkürzungen / Acronyms:

Strkr	Streitkräfte / Armed Forces
FfE	Fachaufsicht führende Ebene / Agency Responsible for Technical Oversight
BA	Bauamt / Building Authority
BK/LB	zuständige Bundeskasse/Landesbank / Relevant Federal Cashier's Office/State Bank

**Settlement of Disputes**

**APPENDIX III**  
**SETTLEMENT OF DISPUTES**

## Settlement of Disputes

### NATO SOFA SA, Article 44 – SETTLEMENT OF DISPUTES

1. In the settlement of disputes arising from contracts concluded by the German authorities for the account of the authorities of a force or of a civilian component there shall at all times be close cooperation between those authorities, whether or not court proceedings are involved. This shall apply mutatis mutandis to disputes arising out of work, personnel representation, or social insurance of civilian labor with a force or a civilian component, as well as to disputes which arise from procedures referred to in subparagraph (c) of paragraph 1 of Article 62 of the present Agreement. Details of such cooperation shall be laid down in administrative agreements.
2. So far as they relate to court proceedings instituted against the Federal Republic, the agreements referred to in paragraph 1 of this Article shall be based on the following principles:
  - (a) The authorities of the force or of the civilian component shall be notified without delay of the lodging of a plaint and shall be consulted at all material stages of the proceedings.
  - (b) The decision as to whether or not an appeal should be lodged shall be taken only in agreement with the authorities of the force or of the civilian component. Failing agreement, the German authorities shall lodge an appeal if an authority of the force or, where applicable, an authority of the civilian component, at highest level, confirms its essential interest in that action being taken. The authorities of the force or of the civilian component shall not object to the lodging of an appeal if a Federal authority at the highest level confirms its essential interest in that action being taken. To the extent that the reasons underlying the confirmation of the interest referred to in the second and third sentences of this paragraph have not become known to the other party in the course of negotiations on the lodging of an appeal, such reasons shall be given on request.
3. Paragraph 2 of this Article shall apply mutatis mutandis to court proceedings instituted by the Federal Republic, it being understood that the principles set out in subparagraph (b) of paragraph 2 shall also be applied to the lodging of plaints.
4. Whether or not court proceedings are involved in the disputes referred to in paragraph 1 of this Article, the German authorities shall terminate such disputes only in agreement with the authorities of the force or of the civilian component.
5. (a) The sending State concerned shall meet all the obligations laid upon, and shall enjoy any benefits accruing to the Federal Republic as a result of judgments, decisions, orders and settlements (vollstreckbare Titel) in the court proceedings arising from disputes referred to in paragraph 1 of this Article.

### **Settlement of Disputes**

- (b) Where, solely as a result of a Federal authority at the highest level having confirmed its essential interest in the lodging of a plaint or an appeal, the force or the civilian component has raised no objection to that action being taken, and if the plaint or appeal gives rise to additional costs in the court proceedings, agreement shall be reached on a case to case basis as to whether and to what extent the obligations arising from such court proceedings are chargeable to the sending State or to the Federal Republic.
  - (c) Costs arising in connection with court proceedings which are not included in the costs awarded by the court shall be paid by the sending State if the force or the civilian component has given its agreement before the costs were incurred.
6. (a) Disputes arising from direct procurement by the authorities of a force or of a civilian component of goods and services in the Federal territory shall be settled by German courts or by an independent arbitration tribunal. Where the German courts are to decide the dispute, the plaint shall be lodged against the Federal Republic, which shall conduct the case in its own name in the interest of the sending State. Paragraphs 2, 4 and 5 of this Article shall apply mutatis mutandis as regards relations between the Federal Republic and the sending State.
- (b) Agreements between the Federal Republic and a sending State shall, however, take precedence over the provisions of subparagraph (a) of this paragraph.

## Settlement of Disputes

### **ADMINISTRATIVE AGREEMENT FOR SETTLEMENT OF DISPUTES (30 JANUARY 1967/17 APRIL 1967)**

Pursuant to Article 44 of the SA to the NATO SOFA concerning the cooperation between the German authorities and the authorities of the US Forces and the civilian component in the settlement of disputes.

#### **1. This Administrative Agreement pertains to disputes.**

- 1.1 Arising from contracts concluded by the German authorities for the account of the authorities of the US Forces or the civilian component (hereinafter referred to as the "Force"), including contracts entered into by the German authorities in accordance with the German-American Administrative Agreements concerning the execution of construction projects.
  - 1.2 Arising out-of-work, personnel representation, or social insurance of civilian labor with the Force, except insofar as the settlement of disputes is controlled by the "Agreement concerning Performance of Payroll Office Functions for Personnel of the European Exchange System (EES)."
  - 1.3 Referred to in subparagraph (c) of paragraph 1 of Article 62 of the SA to the NATO SOFA, i.e., cases in which requisitioning procedures ("Anforderungsverfahren") have been carried out on behalf of the Force under German procurement legislation, with the exception of the Restricted Areas Law and Land Procurement Law.
  - 1.4 Arising from contracts for direct procurement of goods or services by the Force to the extent that they contain no provisions for the settlement thereof and, hence, will be adjudicated in accordance with the second sentence of Article 3 of the Agreement between the FRG and the United States of America on the Settlement of Disputes Arising out of Direct Procurement of August 3, 1959.
2. The German authorities and the authorities of the Force shall at all times closely cooperate in order to settle such disputes. In case of differences of opinion between the German authorities and the authorities of the Force, which cannot be settled on the level of the subordinate agencies, agreement will be reached between Headquarters, United States Army, Europe, APO AE 09403, or Headquarters, United States Air Forces in Europe, APO AE 09094, and the competent highest German federal authorities. This does not affect the instruction under No. 4.4. of this attachment.
  3. Whether or not court proceedings are involved, the German authorities shall terminate such disputes only in agreement with the authorities of the Force.
  4. Where, as a result of such disputes, court proceedings have been instituted against the FRG as the nominal defendant for the United States, the conduct of the litigation shall be as follows:



## Settlement of Disputes

- 4.1 The competent authority of the Force (i.e., Headquarters, United States Army, Europe, APO AE 09403, or Headquarters, United States Air Force in Europe, APO AE 09094, or any agency designated by these headquarters) shall be notified without delay of the lodging of a plaint or the serving of a payment order. In labor and social court cases, this notification shall be addressed to the Civilian Personnel Office of the military district or Air Force installation concerned. The competent authorities of the Force shall be consulted at all material stages of the proceedings. For this purpose, it shall be provided as soon as possible with copies of the documents essential for the litigation, especially the plaint (Klageschrift) or payment order, the replay thereto (Klageerwiderung), appeals (Rechtsmittelschriften), briefs in support of appeals (Rechtsmittelbegründungen), and replies thereto (Rechtsmittelerwiderungen), notification of litigation (Streitverkündigungen), court decisions (gerichtliche Entscheidungen), protocols on the taking of evidence (Beweisaufnahmeprotokolle), proposals for compromise settlements (Vergleichsvorschläge) and compromise settlements (Vergleiche).
- 4.2 When concluding a compromise settlement, the German authority shall reserve the right of revocation within an appropriate period and obtain the consent of the authority of the Force. The authority of the Force shall furnish the German authority its decision in due time to allow a declaration of revocation to the court within the revocation period.
- 4.3 If a decision is issued in favor of the opposing party, the German authority shall examine whether an appeal is admissible and has prospects of success. It shall inform the authority of the Force without delay of its opinion, forwarding a complete copy of the decision and stating the period for lodging an appeal.
- 4.4 The decision as to whether or not an appeal should be lodged shall be mutually agreed by the German authority and the authority of the Force. Failing agreement, the German authority shall lodge an appeal if the authority of the Force at the highest level confirms its essential interest in such action being taken. The authority of the Force shall not object to the lodging of an appeal if an authority of the FRG at the highest level confirms its essential interest in such action being taken. The party insisting on the appeal being taken shall notify the other party, upon request, as to the reason for such appeal.
5. No. 4. of this agreement applies, mutatis mutandis, with respect to court proceedings instituted by the FRG with the understanding that the principles set forth in No. 4.4. of this attachment shall also be applied to the filing of complaints.
6. No's. 4. and 5. of this agreement apply, mutatis mutandis, with respect to court proceedings for the decision of disputes arising out of the personnel representation legislation (Beschwerdeverfahren) in which the FRG takes part on behalf of the Force.
7. All rights or obligations established in favor of or against the FRG by judgments, decisions, orders, or settlements (vollstreckbare Titel) in court proceedings arising from disputes referred to in No. 1. of this attachment shall accrue to the United States or be met by them.

## Settlement of Disputes

8. The United States will bear the expenditures, including attorney fees, incurred by the German authorities in connection with these lawsuits and in taking actions pertaining to the execution of judgments, decisions, orders, or settlements as a result of such lawsuits to the extent they constitute necessary costs of attainment of justice (Rechtsverfolgung und Rechtsverteidigung) (Section 91, German Code of Civil Procedure) and provided that their payment can neither be demanded from, nor be enforced against, the other party, and provided, in the latter case, that the bill for expenditure incurred is accompanied by a statement confirming that collection efforts made have failed.
9. Costs which do not constitute necessary costs of attainment of justice will be borne by the United States only if consent has been obtained from the appropriate authority of the Force prior their accrual.
10. Where, solely as a result of an authority of the Federal Republic at the highest level having confirmed its essential interest in the lodging of a plaint or an appeal, the authority of the Force does not object to that action being taken and if the plaint or appeal gives rise to additional costs in the court proceedings, such additional costs shall be borne by the FRG unless otherwise agreed in the case concerned.
11. The United States shall not be responsible for reimbursement of costs of litigation to the extent to which such costs are established to have been incurred as a result of deliberate intention or gross negligence in the conduct of the litigation by the employees acting for the FRG in the litigation.
12. Amounts payable by the FRG to the opposite party as a result of judgments, decisions, orders or settlements (vollstreckbare Titel) and costs of litigation which are reimbursable by the United States, will be requested by the German authorities from the appropriate authority of the Force not later than 3 months after the conclusion of court proceedings. The request shall be documented by attached vouchers. The competent authority of the Force will pay the amount requested within one month after receipt of the vouchers. In case of judgments, decisions, orders or settlements which are enforceable before they become final (vorläufige vollstreckbare Urteile) payment shall be requested and effected if the opposing party requests immediate payment and execution cannot be precluded otherwise. If in these cases a decision obligating the FRG to effect payment is later reversed, the FRG shall take all appropriate measures to obtain a refund of the amount paid; the amounts reimbursed shall be credited to the Force.
13. If the opposing party is obligated to make payments as a result of judgments, decisions, orders or settlements (vollstreckbare Titel) and does not pay voluntarily within an appropriate period, the German authority will seek execution of such judgments, decisions, orders or settlements. The amounts collected will be set off against those amounts reimbursable to the FRG with regard to the same litigation, and or remitted to the Force.